

# EVO II RTK Series V3

## User Manual

2022.09

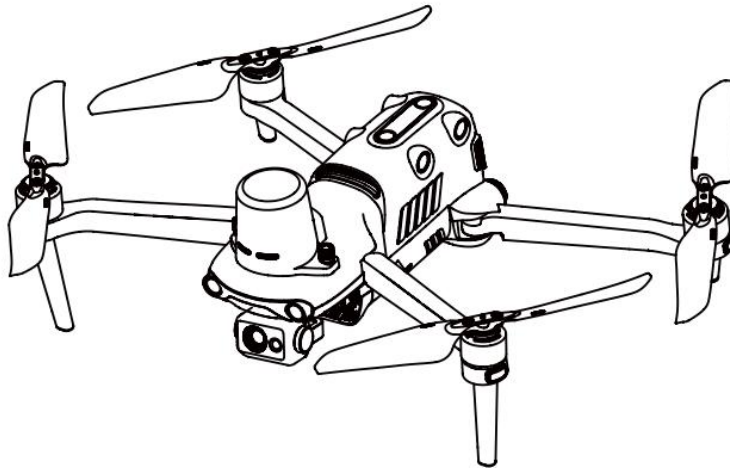

**AUTEL**  
ROBOTICS

## Legend

Pay attention to the following legend keys in this User Manual:



**Warning:** Informs you of potential dangers.



**Important:** Precautions that you should pay attention to during flights.



**Note:** Additional information.



**Tip:** Tips that can help you get the best user experience.



**Reference:** Information that can help you find the page number for relevant chapters.

## Trademark Information

The trademarks EVO II Dual 640T RTK™, EVO II Pro RTK™, Autel Explorer™, Starpoint™, and Autel Robotics® are the registered trademarks of Autel Robotics Co., Ltd. (hereinafter referred to as "Autel Robotics") in China and other countries/regions. All other products and company names mentioned in this User Manual are registered trademarks of their respective holders.

## Copyright

No part of this Manual may be copied or transmitted in any form or by any means, electronic, mechanical, photocopying, recording, or otherwise without the prior written permission of Autel Robotics.

## Patent Information

This product is obtained through a patent process. The following shows the patent numbers:

US7979174

IL192490

US9260184

CA2815885

US9979000

US10224526

US10044013

US10115944

US10090496

US10074836

US10341573

US10399699

US10414514

## **Disclaimer**

To ensure that you can successfully operate your EVO II RTK Series V3 aircraft, please strictly follow the instructions and steps described in this Manual. The aircraft shall be kept out of the reach of children when it is not used.

If you does not abide by the Safety Guidelines, Autel Robotics shall not be responsible for any product damage or loss (whether direct or indirect, legal, special, accident, or economic loss (including but not limited to loss of profit)) during use, and shall not provide any warranty service. Never modify the product using any incompatible component or in any way that does not conform to the official instructions of Autel Robotics.

This User Manual describes the procedures and methods for safely operating the aircraft. Please ensure that the operations you perform do not endanger personal or property safety of yourself or those around you. The Safety Guidelines in this Manual will be updated from time to time. To ensure that you get the latest version, visit [www.autelrobotics.cn/download/11](http://www.autelrobotics.cn/download/11)

## **Data Storage and Use**

The backup service function of this product is turned off by default, meaning that user and flight information will not be uploaded or disseminated via mobile devices. When the Autel Explorer App is connected to the aircraft and the backup option is turned on, flight logs and flight remote sensing data will be automatically uploaded and saved in the Autel Robotics data server. All flight remote sensing data and flight logs can be uploaded automatically only when the flight log backup option is turned on. Unless the user explicitly grants permission through the Autel Sky App, the Autel Robotics Customer Service Team has no right to access the flight log data. After this permission is granted, only flight logs within the selected date range can be accessed.

Various still images, motion images, and data transmitted from the aircraft sensor will be stored on the internal drive of the aircraft. If your drone needs to be repaired, you can use the information stored on the internal storage unit to diagnose the drone's problem. This information will not be retained unless for service processing and product repairing. Do not delete or change the data on the internal storage device. Otherwise, Autel Robotics shall provide no warranty service. The purpose of Autel Robotics' collection of data is to provide customers with support and services, and to improve product performance. We take your right to privacy very seriously. We will only agree to the disclosure of uploaded data when required by law. For

details about the privacy policies, visit [www.autelrobotics.cn/page/privacy](http://www.autelrobotics.cn/page/privacy).

## Safety Guidelines

### Battery Safety

EVO II RTK Series V3 is powered by lithium-ion polymer (LiPo) batteries. Improper use of LiPo batteries may cause danger. Strictly observe the following safety guidelines when using, charging, or storing your batteries.

---

#### **Warning**

- Use batteries and chargers provided only by Autel Robotics. Do not modify the battery pack and the recharger or replace them with third-party devices.
  - Electrolytes in the battery are highly corrosive. If any electrolytes make contact with your skin or eyes, immediately wash the affected area with fresh running water and then see a doctor.
- 

### Battery Use

When installing or removing the aircraft battery, be sure to turn off the aircraft's power. Other precautions are as follows:

- Only use batteries and charging devices sold or authorized by Autel Robotics for EVO II RTK Series V3. Using unapproved batteries or charging devices may cause fire, explosion, leakage or other hazards. Autel Robotics is not responsible for any repercussions caused by the use of third-party batteries or charging devices.
- Do not disassemble, scratch, squeeze, bend, puncture, cut, twist, or otherwise intentionally damage the battery. Otherwise, it may cause fire, explosion, leakage, or other hazards.
- Once the battery begins to bulge, smoke, leak, or show any other signs of damage, stop using it immediately and immerse it in a container filled with salt water.
- Use the battery at a suitable temperature (-10°C to 40°C). Using the battery at a high or low temperature will affect the battery life. Extreme temperatures may cause fire, spontaneous combustion, or permanent damage.
- Exposing the battery below 5°C will increase the battery discharge rate.
- Do not use the battery in a strong electrostatic or electromagnetic environment.
- Do not expose the battery to open flame, explosives, or other hazards.

- If the aircraft falls into water, remove the battery immediately after recovering it. Put the battery in an open place and keep a safe distance until it is completely dry. After that, stop using the battery. You can contact our Customer Service Team to replace it.

### **Battery Charging**

It takes up to 90 minutes to fully charge the aircraft battery, but the charging time is related to the remaining power.

Other precautions are as follows:

- Do not use damaged battery chargers.
- When the charger is not in use, disconnect it from the aircraft battery and power supply.
- Do not charge the battery until it cools down to near room temperature. If you connect the battery to the charger immediately after the flight, the over-temperature protection may be automatically activated, preventing the battery from charging until it has completely cooled.

### **Battery Storage**

Avoid close contact with water or heat sources when storing the battery.

The battery should be stored in a dry, well-ventilated area at room temperature (ideally 22°C to 28°C).

Other precautions are as follows:

- Keep batteries out of the reach of children and pets.
- Do not store the battery near direct sunlight, sharp objects, water, metal or reactive chemicals.
- Storing the battery at extreme temperatures will shorten its life.
- If the battery is not used for more than 6 days, it should be stored at a temperature of -10°C to 30°C.
- If left unused for an extended period of time, the service life of the battery will be shortened.

### **Battery Disposal**

- Please fully discharge the battery before the disposal.
- Dispose of the battery in a designated battery recycling bin.

### **Flying the Aircraft Safely**

#### **Flight Environment**

- Please abide by all local regulations regarding drone flight. Only fly in

designated UAV flight areas. Use the Autel Explorer App to set the distance and height restrictions that meet the regulations.

- Do not fly in dangerous situations or severe weather conditions such as tornadoes, rain, hail, snow, etc.
- Do not fly the aircraft near electromagnetic interference sources such as power plants, power lines, substations, wind turbine towers, and radio and television towers.
- Fly in an open safe area. Keep the aircraft away from obstacles that may interfere with GPS signals, such as buildings and trees.
- Be careful when flying the aircraft in areas 7000 meters above sea level as the battery and motor performance may be affected.

### **Before Takeoff**

Please do the following before each flight:

- Ensure that the remote controller, aircraft battery, and mobile device on which Autel Explorer App is installed are fully charged.
- Ensure that the propeller is installed correctly and is not damaged.
- Ensure that the front arm and rear arm of the aircraft are fully unfolded.
- Make sure the motor, gimbal and camera work normally after the aircraft is powered on.
- Ensure that all warnings and errors displayed on the Autel Explorer App have been handled.
- Only use accessories provided with this aircraft or ones that are sold or authorized by Autel Robotics for this product. Using unapproved accessories can result in serious safety risks and will void the product warranty.

### **In Flight**

- When taking off and landing the aircraft, stay away from people, vehicles and other moving objects.
- Do not let the aircraft leave your sight.
- Do not let the aircraft approach the water when flying it.
- When a low battery alarm occurs, do not cancel the auto-return process. Otherwise, the aircraft may not be able to return to the home point due to insufficient battery power.
- When the Autel Explorer App displays an alarm, follow the corresponding instructions immediately.
- Do not attempt to operate the aircraft if you are inebriated or experiencing high blood pressure, dizziness, fatigue or any other physical conditions that

may affect your ability to safely operate the aircraft.

---

 **Warning**

- If any part of the aircraft or the remote controller fails to work normally or is visibly damaged, do not fly. Contact the Autel Robotics Customer Service Team: [www.autelrobotics.cn/page/service](http://www.autelrobotics.cn/page/service)
- 

**Storage and Maintenance**

After any collision or squeeze, every part of the aircraft should be checked carefully. Store the aircraft and its accessories in places out of the reach of children and pets.

- Store the aircraft and its accessories in a cool, dry place.
- The aircraft should be kept away from water and heat sources.
- The recommended storage temperature for the aircraft is 22°C to 28°C.

# Table of Contents

<b>Chapter 1 About This Manual .....</b>	<b>11</b>
1.1 Read Before the First Flight .....	11
1.1.1 Document .....	11
<b>Chapter 2 Product Profile .....</b>	<b>12</b>
2.1 Aircraft .....	12
2.1.1 Component Description .....	12
2.1.2 Flight Status Indicator .....	14
2.1.3 Aircraft Battery .....	15
2.1.4 Gimbal and Camera .....	19
2.1.5 Flight Control System .....	24
2.1.6 Intelligent Flight Features .....	26
2.1.7 Omnidirectional Binocular Vision Sensing System .....	28
2.2 Remote Controller .....	32
2.2.1 Component Description .....	32
2.2.2 Use the Remote Controller .....	34
2.3 RTK module .....	37
2.3.1 Use the RTK Module .....	37
2.4 Autel Explorer App .....	38
2.4.1 Mission .....	38
<b>Chapter 3 Flight Preparations .....</b>	<b>42</b>
3.1 Prepare the Battery .....	42



3.1.1 Install the Aircraft Battery .....	42
3.1.2 Remove the Aircraft Battery .....	42
3.1.3 Charge the remote controller .....	42
3.2 Prepare the Remote Controller .....	44
3.2.1 Unfold the Remote Controller .....	44
3.2.2 Turn On/Off the Remote Controller .....	44
3.2.3 Pair the Aircraft with the Remote Controller .....	44
3.3 Prepare the Aircraft .....	45
3.3.1 Unfold the Aircraft .....	45
3.3.2 Propeller .....	45
3.3.3 Compass Calibration .....	47
<b>Chapter 4 Flight Operation .....</b>	<b>49</b>
4.1 Pre-flight Checklist .....	49
4.2 Flight Operation .....	49
4.2.1 Takeoff (Mode 2) .....	49
4.2.2 Control with Command Sticks (Mode 2) .....	50
4.2.3 Landing .....	52
<b>Chapter 5 Maintenance and Service .....</b>	<b>53</b>
5.1 Firmware Updates .....	53
5.2 Troubleshooting .....	54
5.3 Storage and Maintenance .....	56
5.4 Warranty .....	56

5.5 Customer Service .....	57
5.5.1 Technical Support .....	57
5.5.2 Maintenance Service .....	57
<b>Chapter 6 Appendix .....</b>	<b>58</b>
6.1 Unlock No-Fly Zones .....	58
6.2 Specifications .....	59

# Chapter 1 About This Manual

Thank you for purchasing EVO II RTK Series V3. In this Manual, you will learn detailed product features and the best way to operate the aircraft and remote controller. Please read this Manual and other attached documents prior to the initial operation of the product and keep the User Manual for later use.

## 1.1 Read Before the First Flight

### 1.1.1 Document

The following documents will walk you through how to operate an EVO II RTK Series V3 aircraft for the first time.

1. **Product list:** A list of all the items included in the packing box. If anything is missing, contact Autel Robotics customer support or local retailers.
2. **User Manual:** Teaches you how to operate the product in a skillful way.
3. **Quick Guide:** Provides basic knowledge about how to operate the product.
4. **Disclaimer and Safety Operation Guidelines:** Provides instructions on how to safely operate the product.
5. **Battery Quick Guide:** Provides basic knowledge about intelligent batteries.

Website for downloading all the documents: [www.autelrobotics.cn/download/11](http://www.autelrobotics.cn/download/11).

---

#### **Warning**

- Please check the aircraft and other accessories listed on the part list in packing box. Do not modify this aircraft by using any incompatible component or any method that is not allowed in the official description.
-

## Chapter 2 Product Profile

EVO II RTK Series V3 is integrated with an entirely new RTK module, which provides real-time centimeter-level positioning data. Equipped with a 640×512 thermal imaging camera and a 4K visual camera, EVO II Dual 640T RTK V3 enables you to capture thermal images and visual light images at the same time and supports "Picture-in-Picture" mode. EVO II Pro RTK V3 is delivered with 6K high-definition lens that are supported by an 1-inch CMOS sensor. It also comes standard with a 7.9-inch 2000nit high-definition remote controller, enabling real-time transmission of 1080P video images.

The aircraft adopts a foldable fuselage design, making it portable and convenient to fly. With a maximum transmission distance of 15 km (FCC), the aircraft offers a flight time of up to 36 minutes, and can reach a top speed of up to 72 km/h.

The body of the aircraft has 12 visual sensors, providing omni-directional obstacle avoidance. The Autel Explorer App provides users with dozens of intelligent photography modes and multiple mission flight modes such as rectangular missions, polygonal missions, waypoint missions, and oblique. You can plan the waypoints and flight routes as required.

### 2.1 Aircraft

#### 2.1.1 Component Description

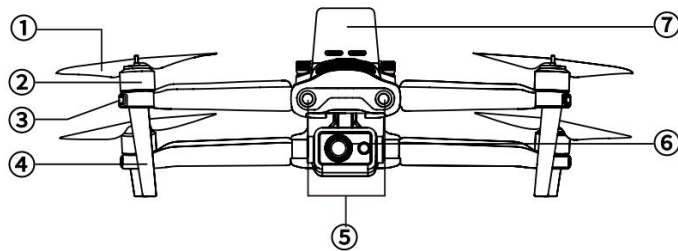

- |                       |                         |
|-----------------------|-------------------------|
| ① Propeller           | ⑤ Forward Vision System |
| ② Motor               | ⑥ Gimbal Camera         |
| ③ Front LED Indicator | ⑦ RTK Module            |
| ④ Landing Gear        |                         |

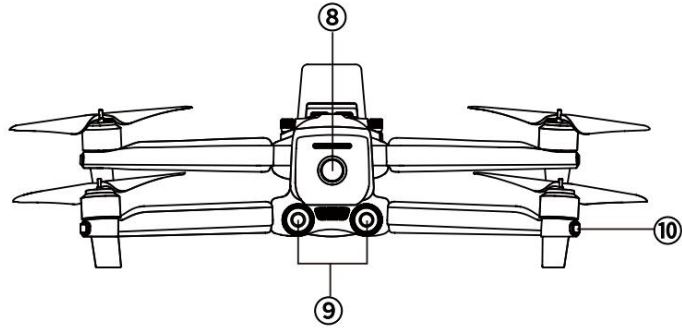

- ⑧ Power Button
- ⑨ Rear Vision System
- ⑩ Rear LED Indicator

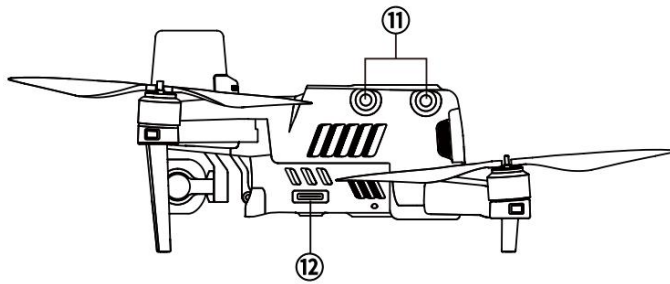

- ⑪ Left Vision System
- ⑫ SD Card Slot

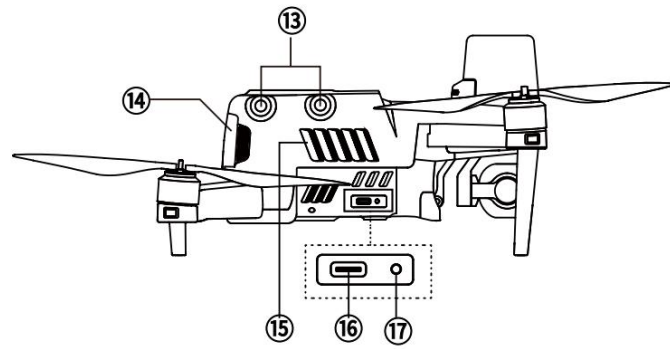

- ⑬ Right Vision System
- ⑭ Aircraft Battery
- ⑮ Air Outlet
- ⑯ USB-C Port
- ⑰ Linking Button/Indicator

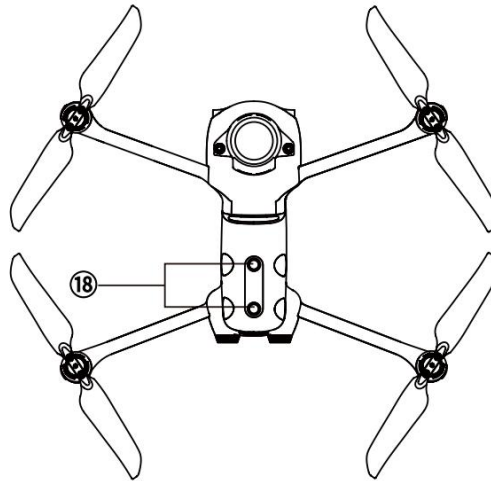

⑱ Upward Vision System

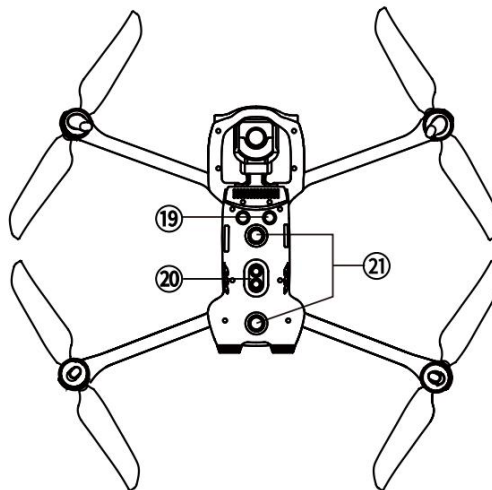

⑲ Ultrasonic Sensor

⑳ LED Fill Light

㉑ Downward Vision System

---

 **Note**

- The right side of the aircraft body has a protective cover that can protect USB-C ports and linking button/indicator. Please ensure that the protective cover is closed during the flight.

---

### 2.1.2 Flight Status Indicator

The aircraft has an LED indicator at the end of each arm. The front LEDs glow solid red to identify the orientation of the nose of the aircraft. The rear LEDs show the

current flight status of the aircraft. The following table describes the meaning of each LED state.

<b>Indicator:</b>	<b>Color:</b>
<b>Flash slowly:</b> Flash one time every 2s.	<b>R</b> Red
<b>Flash quickly:</b> Flash two times every second.	<b>G</b> Green
<b>Flash alternately:</b> Flash between different colors in an alternating fashion.	<b>Y</b> Yellow

<b>Status Definition of LED Indicators</b>	
<b>Normal</b>	
RGY - Flash alternately	System self-check
YG - Flash alternately	Warming up
G - Flash slowly	The aircraft is in GPS mode
<b>Warning</b>	
Y - Flash slowly	The aircraft is in ATTI mode
Y - Flash quickly	There is no connection between the aircraft and the remote controller
R - Flash slowly	Low battery warning
R - Flash quickly	Critical low battery warning
R - Normally on	Critical error or IMU error
RY - Flash alternately	Compass error, requiring calibration/ magnetic interference
<b>Compass Calibration</b>	
Y - Flash quickly	Prepare to calibrate the compass/ The aircraft is being calibrated
G - Normally On	Calibration succeeded
R - Normally On	Calibration failed

### 2.1.3 Aircraft Battery

The rechargeable LiPo battery used by the EVO II RTK Series V3 features high energy density and capacity. The battery needs to be charged by a designated charger.

## 1. Component Description

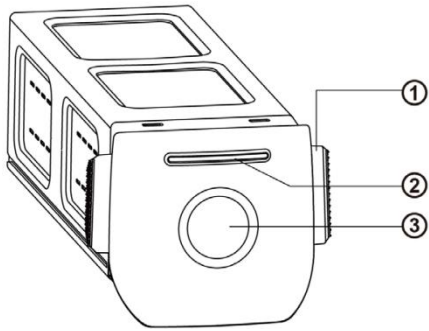

- ① Battery Removal Button
- ② Power Indicator
- ③ Power Button

### ● Turn on the battery

Make sure that the aircraft is turned off before you install the battery. After you install the battery, press the power button for 3s. The battery indicator will show the current battery level.

### ● Turn off the battery

Long press the power button for 3s to turn off the battery. If you have already installed the battery onto the aircraft, the two LED indicators on the nose and tail of the aircraft will flash 5 times, indicating that the aircraft is being shut down. Remove the battery from the aircraft when all power indicators are turned off.















### ● Check the battery level

When the battery is turned off, press the power button for 1s and quickly release it to check the battery level. The LED indicators will show the current battery level, as shown below.

Battery Power Indicator Status (Not in the Charging State)			
0%~12%	13%~25%	26%~37%	38%~50%
51%~62%	63%~75%	76%~87%	88%~100%
- Green LED is normally on	- Green LED flashes	- Off	



## 2. LED Warning Description

LED 1	LED 2	LED 3	LED 4	Warning Description
				The temperature is too high or low for charging.
				The charging current is too high that has caused a short circuit.
				A circuit overcurrent, a circuit overload, or a short circuit occurs during battery discharge.
 - LED flashes  - Off				

## 3. Additional Functions

The following functions can be used to protect and extend the battery life:

- **Storage Self-Discharge**

If the battery is stored in a high-temperature environment or has not been used for 6 days but the battery power is still high, the self-discharge protection mechanism will be activated. The battery will automatically discharge to a level that is safe. This is a default setting and the discharge takes about 2-3 days. Although there is no prompt message indicating that the battery is self-discharging, you may notice that the battery feels slightly hot. This is normal. You can customize the battery discharge threshold using the Autel Explorer App.

- **Sleep Mode Protection**

If the battery is low, it automatically enters the sleep mode to prevent damages. In this mode, there is no response if you press the power button. To wake up the sleeping battery, you must connect it to a charger.

- **Charging Temperature Detection**

The battery stops charging if the temperature is lower than 5°C or higher than 45°C.

- **Overcurrent Protection**

The battery stops charging if the charging current exceeds 8A.

- **Overcharge Protection**

The charging automatically stops if the battery is full.

- **Balance Protection**

The voltage of each battery cell is balanced to prevent overcharge or overdischarge.

- **Overdischarge Protection**

When the battery is not used, after the self-discharging is completed, the battery will be automatically disconnected for power output. This function is not disabled during flight.

- **Short Circuit Protection**

The power is cut off once a short circuit is detected.

- **Battery Saver Mode**

The battery will be turned off if no operation is performed within 30 minutes.

- **Communication**

When the battery is in use, it is continuously synchronized with the aircraft for providing real-time information, including the voltage, capacity, current, and temperature.

- **Ultra Low Power Mode**

To save electricity, when the battery is idle for 6 days and the voltage is lower than 11.6 V, the battery enters this mode. The battery will return to the normal state after you connect it to a charger.

### 2.1.4 Gimbal and Camera

The aircraft has a high-precision 3-axis gimbal, which keeps the camera steady during the flight and allows you to capture clear and stable images. To ensure that the gimbal can work properly, the gimbal temperature must keep between  $-10^{\circ}\text{C}$  and  $50^{\circ}\text{C}$ . You can pitch or tilt the gimbal ( $-30^{\circ}$  degrees to  $90^{\circ}$  degrees) using a dial on the remote controller or an Autel Explorer App.

#### 1. EVO II Pro RTK V3 Gimbal

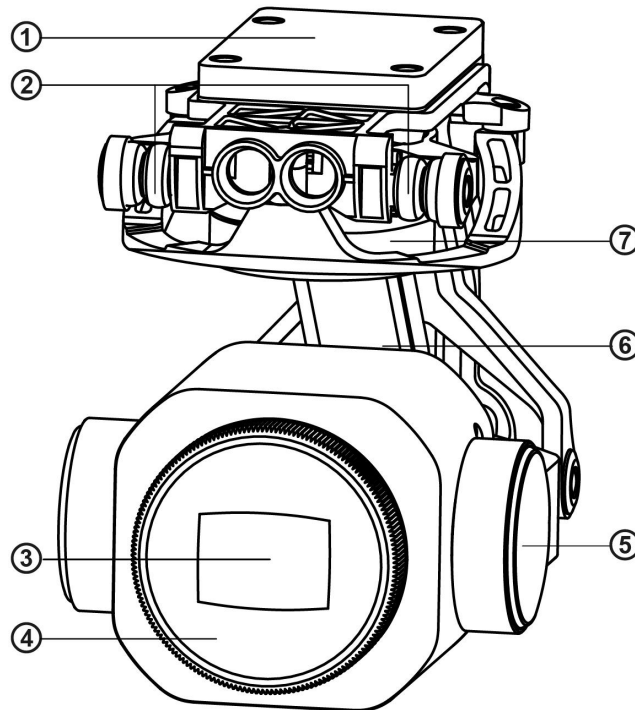

- ① MCU Mounting Plate
- ② Vibration Absorber
- ③ Camera
- ④ Filter

- ⑤ Pitch Motor
- ⑥ Roll Motor
- ⑦ Yaw Motor

## 2. EVO II Dual 640T RTK V3 Gimbal

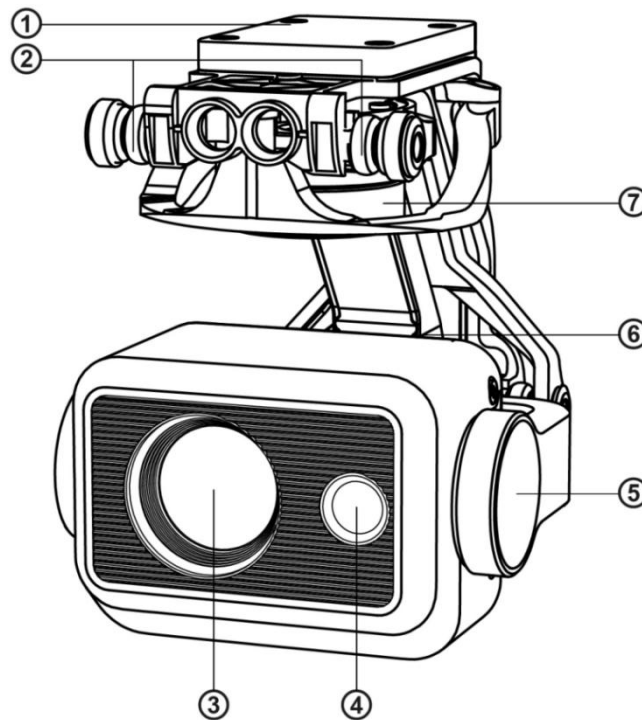

- |                      |               |
|----------------------|---------------|
| ① MCU Mounting Plate | ⑤ Pitch Motor |
| ② Vibration Absorber | ⑥ Roll Motor  |
| ③ Infrared camera    | ⑦ Yaw Motor   |
| ④ 4K camera          |               |

---

### ! Important

- A gimbal protective cover is used for stabilizing the gimbal and preventing the gimbal from rotating accidentally or being damaged during storage.
  - Please remove the gimbal protective cover before you turn on the aircraft. Otherwise, the gimbal motor and circuit may be damaged.
  - When you turn on the aircraft, the gimbal will automatically rotate to perform self-check and calibration. Make sure that there is no object near the gimbal that prevents the movement of the gimbal.
- 

## 3. Gimbal Operation Mode

- **Stabilized mode**

The roll axis remains horizontal and the pitch axis is at a user-defined angle. This mode is suitable for capturing stable horizontal images and videos.

- **FPV mode**

The roll axis is consistent with the rolling direction of the aircraft and the pitch axis is at a user-defined angle. This mode is used for the first-person view.

#### **4. Remove the Gimbal**

1. Place the aircraft on the horizontal surface with the gimbal compartment facing upwards.
2. Use a T6 screwdriver to loosen the two screws that are fixing the gimbal protective cover and then remove the protective cover. Use a cross screwdriver to loosen the screws that are fixing the FPC connector and then pull the connector cable port from the slot.

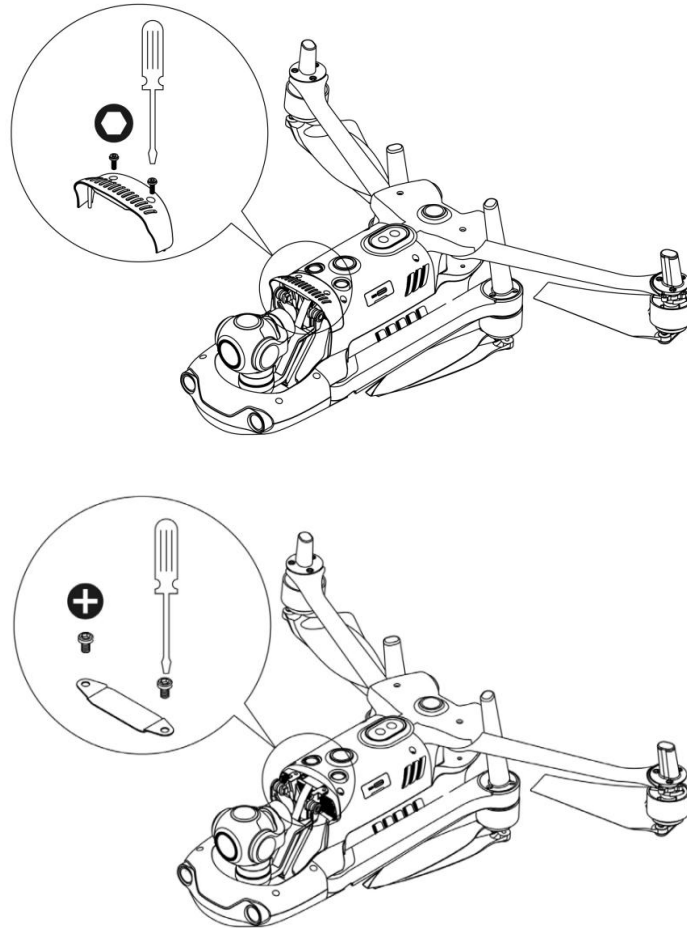

3. Gently pinch the tail of the vibration absorber with your thumb and index finger. Slide the gimbal backwards and upwards along the slot of the gimbal compartment in a straight line.

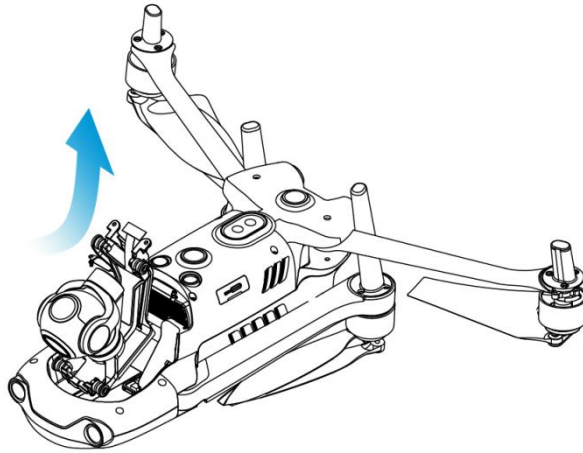

## 5. Mount the Gimbal

1. Pinch the tail of the vibration absorber with your thumb and index finger and lift the gimbal. Slide the gimbal downwards and forwards along the slot of the gimbal compartment in a straight line.

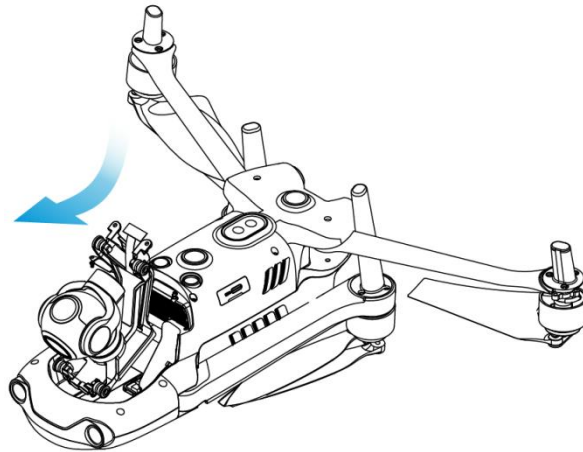

### **!** Important:

- Make sure that the ring at the front of the gimbal is aligned with the two pins in the gimbal compartment at the nose of the aircraft.
  - Make sure that the gimbal is at the same height as the slot of the gimbal compartment.
2. Insert the connector cable port into its slot and gently push it to the end. Place the cover on the top of the gimbal compartment and re-tighten the cover with a cross screwdriver.

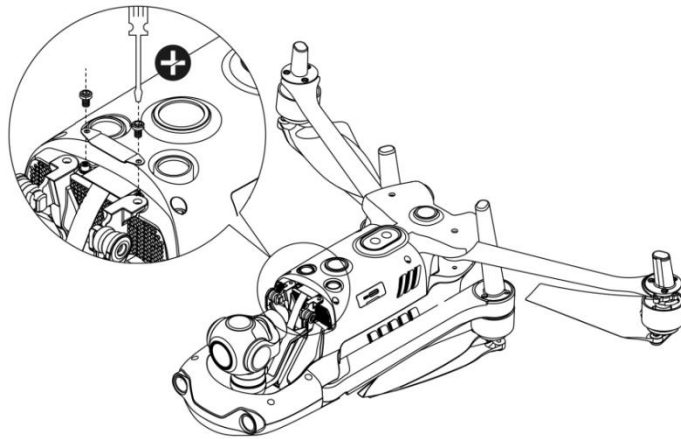

3. Insert a screw into a hole of the decorating part of the gimbal, and then screw it in with a T6 screwdriver until the screw is fixed but not tightened. For the other screw, repeat the same step. Fully tighten the two screws with a screwdriver.

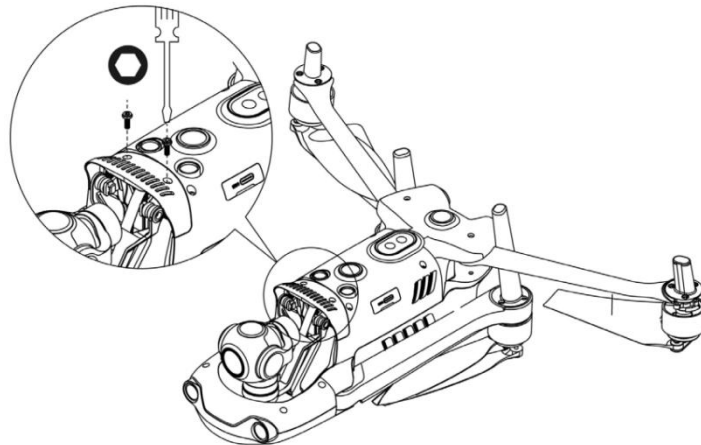

4. Power on the aircraft. If the connector cable is successfully connected, the gimbal will automatically rotate to perform self-check.

## 6. Camera

The camera supports multiple photography modes, including Single, Burst, AEB, Periodic, and HDR. Images are saved in DNG or JPG format while videos are recorded in MOV or MP4 format. Images and videos can be stored in the SD card or the storage device of the aircraft.

- **EVO II Dual 640T RTK V3**

Two kind of cameras are provided: 4k visual cameras and an infrared thermal imaging camera. The thermal imaging camera can work in visual light, infrared light, or in Picture-in-Picture mode. The 4k cameras can record videos at 3840x2160 video resolution and capture 50 million pixels photos. The infrared camera has a resolution of up to 640x512.

- **EVO II Pro RTK V3**

Equipped with a 1-inch sensor, the camera can capture photos with a resolution of up to 20 million pixels and record 5472x3076 P30 videos at a bit rate of 120 mbps or higher. The aperture range is from f/2.8 to f/11.

## 7. Use the Micro SD Card

Before you turn on the aircraft, insert a micro SD card into a port, as shown below. EVO II RTK Series V3 aircraft supports SD cards of up to 256 GB in size. If you plan to record high-definition videos, we recommend that you use a Class 10 or UHS-3 Micro SD card.

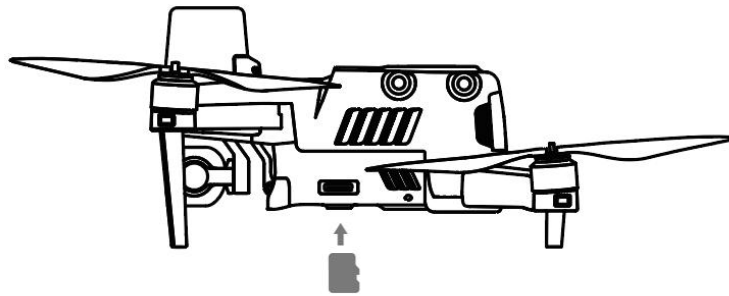

---

### **Warning**

- To protect files on your aircraft, turn off the aircraft before you remove the micro SD card.

---

## 8. Transfer Files to Your Computer

To transfer photos and videos to your computer, connect the aircraft to your computer through a USB-C port, as shown below.

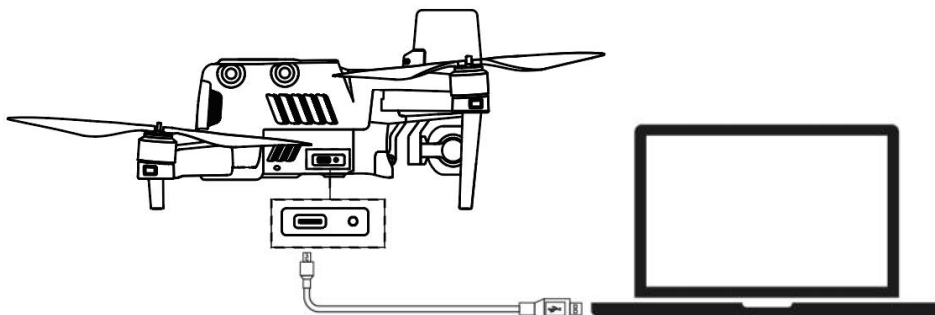

### 2.1.5 Flight Control System

EVO II RTK Series V3 aircraft provides stable and convenient flight control through its built-in intelligent flight control system. The system supports multiple advanced



functions, such as return to home, failsafe, and Starpoint positioning system. Each module is described in the following table.

<b>Intelligent Flight Control System</b>	
<b>Module</b>	<b>Description</b>
IMU	Uses a 3-axis gyroscope and a 3-axis accelerometer to measure the acceleration and angular velocity.
Compass	Measures the geomagnetic field and provides reference information on the heading of the aircraft.
GNSS receiver	Receives signals from global navigation satellite systems and determines 3-D position (latitude, longitude and altitude) of the aircraft.
Barometer	Measures the atmospheric pressure and determines the altitude of the aircraft.
Ultrasonic sensor	Measures the distance between the aircraft and the ground.
Binocular vision sensing system	Supports the omnidirectional binocular vision (front, rear, left, right, up, and down).

## 1. Flight Mode

The aircraft can automatically switch between three flight modes based on the availability of GPS signals and flight conditions.

<b>Flight Mode</b>	
<b>Flight Mode</b>	<b>Description</b>
GPS mode	The aircraft will activate the GPS mode once it detects a sufficient GNSS signal. In GPS mode, with the assistance of the front and rear vision systems, the aircraft can locate and avoid obstacles. GPS provides stable and smooth flight control and supports features such as return to home and failsafe.
ATTI mode	The aircraft automatically changes to ATTI mode when the GPS signal is weak and the vision systems are unavailable as a result of the poor light conditions. The obstacle avoidance feature is disabled and the aircraft controls the altitude through a barometer.
Starpoint mode	In this mode, the aircraft uses the vision positioning, which has a high requirement on the environment and altitude. The

	surrounding environment must have sufficient light and the ground texture must be clear. In addition, the aircraft must fly at an altitude that can be sensed by the vision systems. Otherwise, the aircraft enters the ATTI mode.
--	--

## 2.1.6 Intelligent Flight Features

### 1. Auto-return

This feature is enabled only when the GPS signal is good. To manually activate the auto-return feature, long press the auto-return button () on the remote controller for 3s. After receiving the command, the aircraft will automatically return and land at the preset home point.

EVO II RTK Series V3 aircraft can use its forward vision system to detect and avoid obstacles along the flight route. When the aircraft is returning to the home point, the remote controller is not available and you must press the Pause button () to activate the front vision system.

---

#### **Warning**

- If the forward vision system is not enabled when the aircraft is returning to the home point, the aircraft cannot automatically avoid obstacles. Press the Pause button on the remote controller () to exit the auto-return mode and regain the control over the aircraft.

---

#### **Important**

- The default altitude for returning to the home point is 30 meters. If the auto-return feature is activated when you fly your aircraft at a lower altitude, the aircraft will ascend to the default altitude of 30 meters and then return to the home point.
- If you activate the auto-return feature when the aircraft is within a 10 meters radius of the home point, the aircraft will automatically land at the current place.

---

### 2. Failsafe

Failsafe is to help the aircraft return to the home point automatically or land at the

current place when necessary. Failsafe is activated in the following two scenarios:

- **Communication interrupted**

If the communication between the aircraft and the remote controller is interrupted for 3s, failsafe will be activated.

If a GPS signal is available when the failsafe is activated, the aircraft will automatically return to the home point. Otherwise, the aircraft will land in the current place. After the communication is restored, you can press the Pause button (⏸) to regain the control over the aircraft.

- **Aircraft battery is low**

The failsafe is triggered whenever one of the following error occurs:

- 1). The aircraft continuously calculates the battery power required for returning to the home point. If the battery power is sufficient for the aircraft to return to the home point, the App will show a notification. The failsafe will be activated and the aircraft will start the auto-return process. In the meantime, you can press the Pause button (⏸) to regain the control over the aircraft.
- 2). When the battery level of the aircraft reaches the set threshold (25% by default), you will receive a low battery warning, the failsafe is activated, and the aircraft will automatically return to the home point. If you regain the control over your aircraft, when the battery level reaches 15%, you will receive a critical low battery warning and the aircraft will automatically land in the current place. For any emergency, press the Pause button (⏸) to stop landing and manually fly the aircraft to the nearest safe landing point.

---

 **Note**

- When the battery level of the aircraft reaches 25% (low battery warning), if the horizontal distance between the aircraft and the home point is less than 50 meters (150 ft), the aircraft will not execute the auto-return procedure.
  - If no GPS signal is available when a low battery warning is displayed, the aircraft will not execute the auto-return procedure. The aircraft will enter the ATTI mode and continue to be controlled by you. When the battery level reaches 15% (critical low battery warning), the aircraft will land automatically.
-

### 3. Landing Features

#### ● Landing Protection

When the aircraft arrives above the home point, this feature will detect the ground environment below. If the ground is flat, the aircraft will land automatically. Otherwise, it will hover and wait for the next instruction.

#### ● Accurate Landing

When this feature is activated, the aircraft will land as close as possible to the takeoff point.

---

#### ! Important

- The aircraft will record the takeoff point as the default home point. The accurate landing only takes effect when the home point is not updated during flight.
- Select an open area with sufficient light as the takeoff point.
- To use this feature, make sure that the environment where the aircraft takes off is not changed.
- Landing protection and accurate landing features can be enabled using the App.

---

#### 2.1.7 Omnidirectional Binocular Vision Sensing System

The binocular vision sensing systems on the front, rear, left, right, top, and bottom of the EVO II RTK Series V3 aircraft use image data to calculate the distance between the aircraft and potential obstacles. Once an obstacle is detected, the system will stop the aircraft from flying forwards. The binocular vision systems on the front, rear, and bottom are also equipped with a Starpoint positioning system. This system uses the ultrasonic sensor to calculate the altitude of the aircraft and is combined with the binocular vision camera to obtain the location information through image analysis.

<b>Binocular vision sensing system</b>		
<b>System</b>	<b>Position on the Aircraft</b>	<b>Obstacle Sensing Range</b>
Front	Front of the aircraft	0.5 to 18 m
Rear	Tail of the aircraft	0.5 to 16 m

Left/Right	Rear part on the left and right sides of the aircraft	0.5 to 10 m
Top	Top of the aircraft	0.5 to 10 m
Bottom	Bottom of the aircraft	0.5 to 10 m

The figure below shows the covering angle of each binocular vision sensing system:

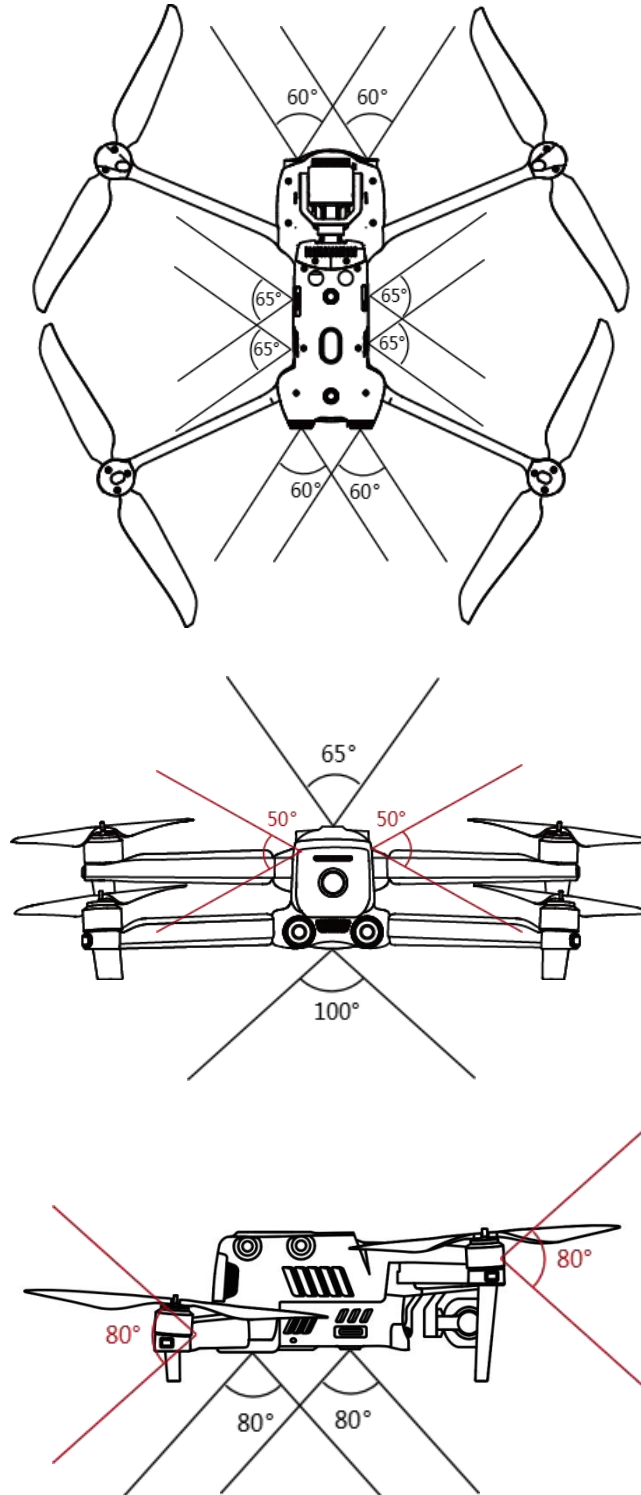

---

 **Note**

- The omnidirectional vision sensing system can sense obstacles in directions such as front, rear, top, bottom, left and right. However, blind areas exist in four diagonal directions. When you fly the aircraft manually, pay attention to the surrounding environment and prompt messages of the App to ensure safety.
  - Do not operate the aircraft in a complex environment with insufficient light, or an area with small objects (such as twig, lines, and nets), moving objects, or objects having transparent surfaces (such as window) or reflected surfaces (such as mirror).
  - In the case of flying along with a vehicle, select an outside field or a closed road for driving. Never use the aircraft on highway.
- 

## 1. Prerequisites

- Ensure that the aircraft is in GPS or vision positioning mode.
- The aircraft should take off when the flight LED indicator flashes green slowly or red twice.
- When the GPS signal is weak or the vision positioning is not available (for example, small visible texture on the object surface or the aircraft is flying at an altitude above 12 meters), you should be extremely careful.
- The binocular vision sensing systems and Starpoint locating systems are affected by the brightness and texture of the objects below the aircraft. Avoid flying the aircraft above the following surfaces:
  - A surface of a pure color
  - A highly reflective surface such as water surface
  - A very bright or dark object surface
  - A surface with frequently changing light
  - Surface composed of highly repetitive patterns such as tile
  - Sound absorbing surface such as thick carpet
  - Moving surface such as road surface with heavy traffic
- Ensure that the binocular camera lens and sensor are kept clean.
- To avoid interference with Starpoint locating systems, do not use a 40 kHz ultrasonic device, such as an ultrasonic range finder, fault detector, cleaner, or welding machine.

## **2. Functionality**

- **Dynamic Tracking**

Using deep learning algorithms, dynamic tracking can detect six objects in real time: walking persons, persons who ride bicycles, moving cars, trucks, ships, and animals. Real-time tracking algorithms can automatically track selected objects and let the aircraft avoid obstacles in its flight path. This feature uses three modes to track objects.

- **Viewpoint**

With the Viewpoint feature, you can now tap on the mobile device screen to let the aircraft fly in the designated direction.

- **Gesture Commands**

Using deep learning algorithms, the main camera identifies and responds to three kinds of gesture commands: straighten your arms upwards to set yourself as the target, hold your arms flat to take a photo, and raise one arm to start or stop recording.

- **Accurate Landing**

The accurate landing feature uses the binocular vision system on the bottom of the aircraft to record the takeoff location. When the aircraft is returning to the home point or landing, vision algorithms are used to calculate the distance between the aircraft and the takeoff point in real time so as to make sure that the aircraft successfully lands at the takeoff point.

- **Safe Landing**

The safe landing feature creates a density depth map using the vision system on the bottom of the aircraft. It calculates the flatness and angle of the depth map to check whether the surface is flat enough to ensure safe landing.

## 2.2 Remote Controller

Portable and highly-reliable, Autel Smart Controller V3 has a 7.9-inch ultra-bright screen, which can clearly display real-time flight information under the strong sunlight. The excellent low-temperature and heat dissipation performance makes it perfectly adapt to harsh environments. The battery can last for 4.5 hours, satisfying the needs of long-time outdoor work. It runs a customized Android system with a built-in Autel Explorer App. You can install third-party apps on it.

### 2.2.1 Component Description

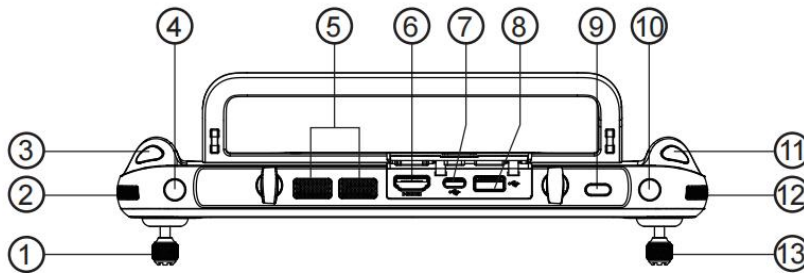

1	Left command stick	Controls the orientation and upward or downward movement of the aircraft.
2	Gimbal dial	Adjusts the gimbal's pitch or tilt angle.
3	Video recording button	Start/stop video recording
4	Custom key C1	Uses the Autel Explorer App for feature settings.
5	Air outlet	Used for heat dissipation for the remote controller.
6	HDMI port	Outputs image transmission signals.
7	Type-C port	Used for charging the remote controller.
8	USB port	Expandable 4G/5G module
9	Power button	Long press the button for 2s to turn the remote controller on or off.
10	Custom key C2	Uses the Autel Explorer App for feature settings.
11	Photo taking button	Takes photos.
12	Zoom setting dial	Adjusts the zoom level of the camera
13	Right command stick	Controls the horizontal movement of the aircraft in four directions (front, rear, left, and right).



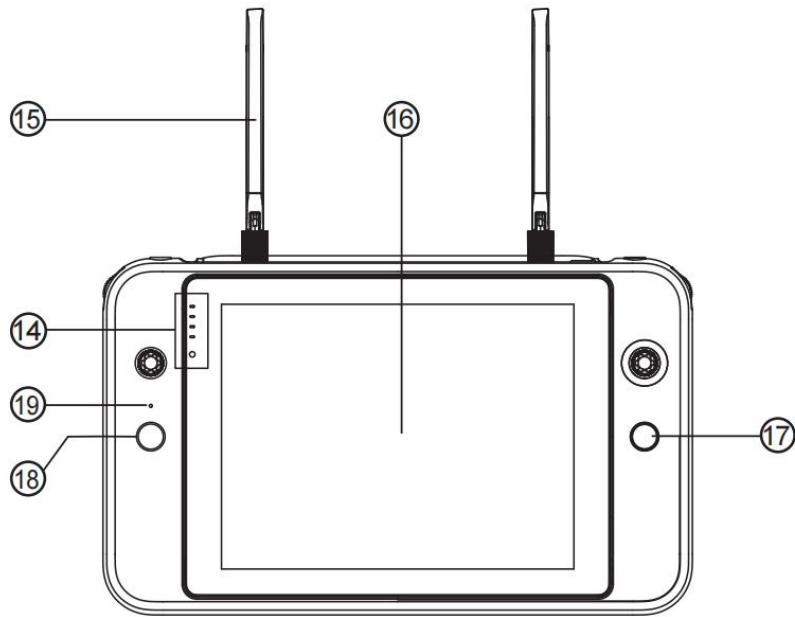

14	Power indicator	Indicates the current battery level of the remote controller.
15	Antenna	Communicates with the aircraft.
16	Display	Displays the image transmission screen and supports tapping operations.
17	Pause button	Instructs the aircraft to stop flying and hover in the current place or resume flying.
18	Auto-takeoff/return button	Instructs the aircraft to take off or return to the takeoff point.
19	Microphone	Receives audio recordings.

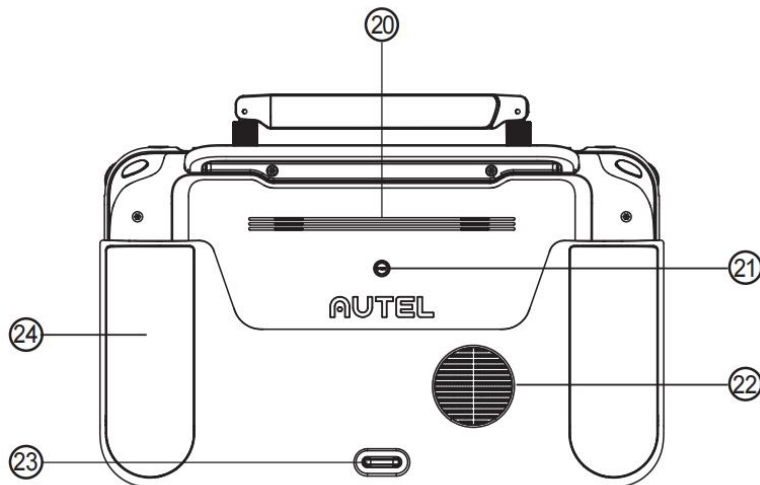





20	Horn hole	Plays recordings or messages about aircraft statuses.
21	Standard 1/4 interface	Used for connecting to the tripod.
22	Air inlet	Used for heat dissipation for the remote controller.
23	Lower hook	Used for fixing the strap on the remote controller.
24	Protective cover	Prevents external damage such as collision and wear of the remote controller.

## 2.2.2 Use the Remote Controller

### 1. Check the battery level

Press the power button to view the battery level of the remote controller.

	
1 LED indicator is normally on: battery level $\geq 25\%$	2 LED indicators are normally on: battery level $\geq 50\%$
	
3 LED indicators are normally on: battery level $\geq 75\%$	4 LED indicators are normally on: battery level = 100%

### 2. Turn on/off

Press the power button for 2s to turn the remote controller on/off.

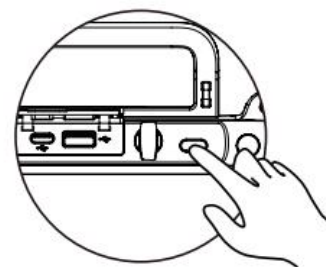

### 3. Charge the remote controller

Connect one end of the charging cable to the USB port on the top of the remote controller, and the other end to an AC power supply (100-240V) through the adapter.

 **Note**

- During charging, the LED indicators flash in turn. All LED indicators are on when the battery is full.
- 

#### 4. Adjust the antennas

Extend the antennas of the remote controller. The strength of the signal received by the antennas varies depending on their positions. The strongest signal can be achieved when the antennas and the back of the remote controller form an angle of 180° or 260° degrees and the flat side of the antennas is facing the aircraft. When you operate the aircraft, make sure that the aircraft is in the place for best communications.

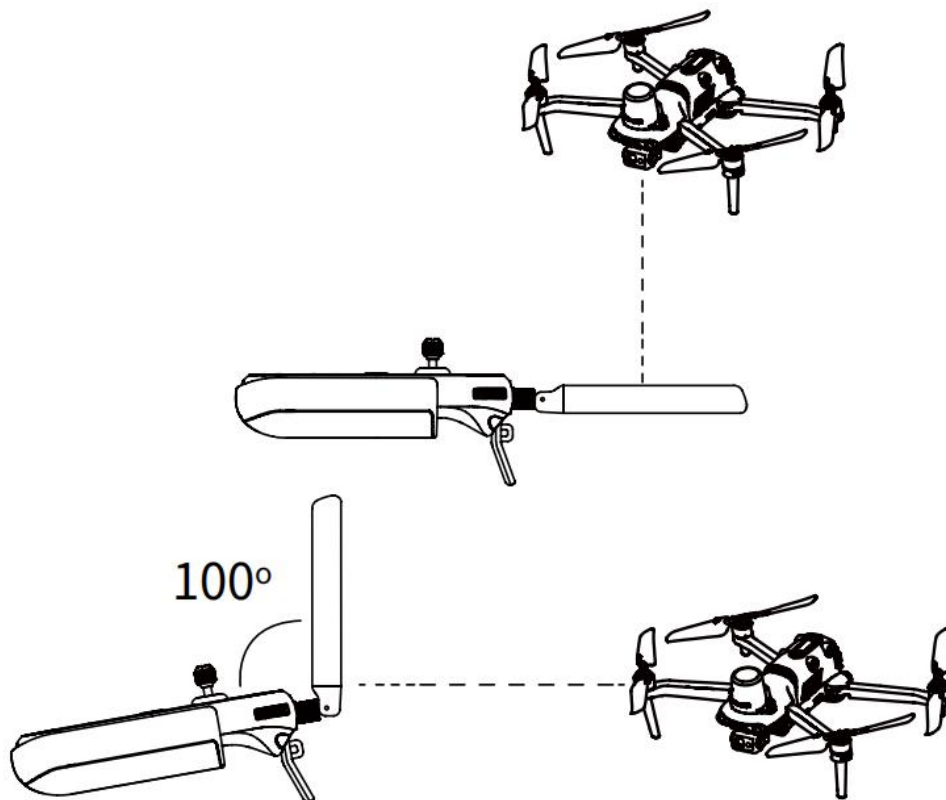

 **Note**

- Do not use other communication devices of the same frequency band at the same time to prevent interference with the signals of the remote controller.
- In practices, when the image transmission signals are weak, the Autel Explorer App will display prompt messages. Adjust the antennas according to the prompted instructions and ensure that the aircraft is in the place for best communications.

---

## 5. Linking

When you buy a whole package that includes an aircraft and a remote controller, the remote controller is already linked to your aircraft before delivery. You can directly use the aircraft after you activate it.

In other cases, you need to manually link the remote controller to your aircraft. Perform the following steps to do that.

1. Press the linking button next to the USB port on the right of the aircraft body to let the aircraft enter the linking state.
2. Turn on the remote controller and launch the Autel Explorer App. Go to the mission flight page, click the wheel icon on the upper right corner to go to the settings menu. Click "Remote Controller -> Data Transmission and Image Transmission Linking -> Start Linking" and wait for several seconds until the linking is successful.

## 6. Calibrate the remote controller

If the stick works improperly, we recommend that you calibrate the remote controller. You can use the Autel Explore App to calibrate the remote controller or perform the following steps:

1. Turn on the remote controller. Go to App camera page. Then click Setting (⚙️) -> Remote Controller -> Remote Controller Calibration. Two ✳️-shaped and two horizontal bars will appear on the screen, representing the left and right command sticks and dials, respectively.
2. Stick calibration: Push and hold the stick one by one in eight directions until you hear a beep each time.
3. Dial calibration: Turn the dial clockwise until you hear a beep and then turn it counterclockwise until you hear another beep.

## 7. Command stick mode

Three command stick modes are provided: mode 1, mode 2, and mode 3. You can set this in the Autel Explorer App based on your own preferences. By default, "Mode 2" is used by the remote controller. In this mode, you can move the left command stick to control the elevation and heading of the aircraft and move the right command stick to control the forward and backward pitch of the aircraft and left or right orientation.

## 2.3 RTK module



### 2.3.1 Use the RTK Module

#### 1. Enable/Disable RTK Module

Go to the camera page of the Autel Explorer App, click the Settings button () in the upper right corner, and select RTK to enable/disable RTK.

#### 2. Use the Network RTK Service

You can connect the RTK module to the third-party network RTK server that supports the NTRIP protocol for receiving and sending differential data. Make sure that you turn on the remote controller and connect it to a network.

1. Make sure that the remote controller has already been connected to the aircraft and the network.
2. Go to the camera page of the Autel Explorer App, click the Settings button () in the upper right corner, select RTK, and then set the RTK service type to "Network RTK". Autel Robotics has already provided the designated network RTK package. You do not need to purchase it within the validity period. If the package expires, you need to purchase it on your own.
3. Wait for the connection with the network RTK server to be set up. If the network RTK status icon () appears in the menu options of the Settings menu, the aircraft has already obtained and used the RTK data.

## 2.4 Autel Explorer App

### 2.4.1 Mission

EVO II RTK Series V3 aircraft can be widely applied in security, inspection, and other industries. You can select multiple mission modes such as waypoint, rectangular, polygon, and oblique through the Autel Explorer App.

#### 1. Waypoint

You can add waypoints by yourself and set parameters and actions of each waypoint. The waypoints are connected in order, forming a flight route. After you call and execute a waypoint mission, the aircraft will automatically fly along the route and perform predefined actions at each waypoint.

1. Click "Mission" on the main app page and select "Waypoint" to go to the planning page.
2. Add a waypoint to the map and set corresponding parameters and actions for the waypoint.
  - Flight altitude: the altitude of the aircraft at a waypoint relative to the home point. The aircraft will gradually fly to the preset altitude on the way to the waypoint. Click Waypoint, select "Flight Altitude", and slide left or right to change the value.
  - Flight speed: the flight speed of the aircraft when it is flying to the waypoint. The aircraft will adjust the flight speed to the preset value on the way to the waypoint. Click Waypoint, select "Flight Speed", and slide left or right to change the value.
  - Action: Click Waypoint, select "Action", and set the waypoint actions and camera actions. Waypoint actions include "Fly Over" and "Hover".
    - A. If you select "Fly Over", the camera actions available include "Photo taking", "Time lapse", "Distance lapse", "Start recording", "Stop recording", and "No action".
    - B. If you select "Hover", the camera actions available include "time lapse" and "video recording (1 - 10s)".
  - Gimbal pitch: the pitch angle of the gimbal when the aircraft flies to the waypoint (range: 0° - 90°). Click Waypoint, select "Action", add camera actions, and slide left or right to adjust the gimbal angle.
  - Yaw angle: the heading of the nose of the aircraft when it flies to this waypoint. Click Waypoint, select "Action", add camera actions, and select the yaw angle mode.
    - A. Route: The aircraft will turn to the next waypoint along the designated

route.

- B. Manual: you can use the remote controller to control the heading of the aircraft.
  - C. Custom: you can set the yaw angle of each waypoint.
  - D. Longitude and latitude: you can adjust the longitude and latitude of a waypoint.
- Associated POI: The main purpose of a POI is to describe the address of an object or an event, such as banks, schools, hospitals and other geographical entities. Edit POI > Click POI > Link Waypoint.

## 2. Regional Mission

You can select three types of regional missions (rectangular, polygon, and oblique). You can set flight parameters of the aircraft and the system will calculate and plan the flight route.

1. On the main app page, click "Mission" and select a rectangular mission, a polygon mission, or an oblique mission to go to the planning page.
  2. Create a project to manually move, zoom out, or zoom in the mission region. After you select a region, click the menu on the bottom to modify parameters.
- Rectangular mission: generate a rectangular region. The aircraft will fly in a bow-shaped route if the double grid is disabled. This is suitable for collecting orthophoto data. The aircraft will fly in a route whose shape is like a pound key if the double grid is enabled. This is suitable for 3D modeling.
  - Polygon mission: generate a polygon-shaped region. The aircraft will fly in a bow-shaped route if the double grid is disabled. This is suitable for collecting orthophoto data. The aircraft will fly in a route whose shape is like a pound key if the double grid is enabled. This is suitable for 3D modeling.
  - Oblique mission: The generated route consists of a normal course and four oblique courses, which is suitable for precise 3D modeling.

	Rectangular	Polygon	Oblique
Flight altitude	√	√	√
Oblique altitude	√	√	√
GSD (GSD)	▲	▲	▲
Oblique GSD	×	×	▲

	Rectangular	Polygon	Oblique
Flight speed	√	√	√
Oblique speed	×	×	√
Front overlap	√	√	√
Oblique front overlap	×	×	√
Side overlap	√	√	√
Oblique side overlap	×	×	√
Gimbal pitch	√	√	√
Oblique pitch angle	×	×	√
Finish action	Go home/hover	Go home/hover	Go home/hover
Course angle	√	√	√
Double grid	√	√	×
Note	√-Adjustable ×-Non-adjustable ▲-Only show the number. Non-adjustable		

---

 **Note**

- Front overlap: the amount of overlap from one image to the next along the flight direction. Side overlap: the amount of overlap between each leg of a flight. When the aircraft is capturing at a low altitude or in regions with even surfaces (such as water, desert, field, vegetation, etc.), increasing the overlap is conducive to image stitching and processing in the later stage.
  - GSD: It refers to the actual physical size that a pixel represents. The smaller the value, the more clear the image.
- 

 **Important**

If one of the following errors occur, the mission automatically ends and the aircraft will perform the corresponding operations:

- **Low battery:** A message is displayed on the app interface, informing you that



the aircraft will automatically return to the home point.

- **Critical low battery:** The aircraft will end the mission and automatically land in the current place.
  - **GPS signal too weak:** The aircraft will enter the ATTI mode and switch to manual control.
- 

### 3. Mission History

You can name and save a flight mission. Missions are displayed in the order of the creation time. The most recently saved missions are at the top of the list while the ones that are saved earlier ago are at the bottom. In addition, you can search (🔍) for a file name to find the corresponding historical mission.

## Chapter 3 Flight Preparations

EVO II RTK Series V3 aircraft adopts a unique convenient design and has been all assembled in the factory. To ensure that you fly the aircraft safely, read the following instructions and warnings before your first flight.

### 3.1 Prepare the Battery

#### 3.1.1 Install the Aircraft Battery

1. Turn the battery switch to off before you install the battery.
2. Insert the battery into the battery compartment, as shown in the figure on the right. You will hear a clicking sound when the battery is installed correctly.

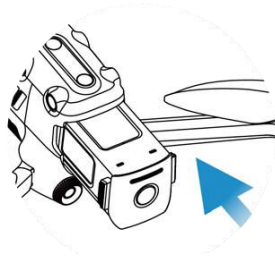

#### 3.1.2 Remove the Aircraft Battery

1. Turn the aircraft battery switch to off before you remove the battery.
2. Press and hold the clips on both sides of the battery and slowly pull the battery out.

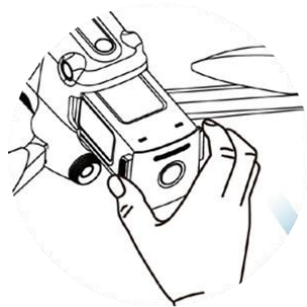

#### 3.1.3 Charge the remote controller

1. **Battery of the aircraft:** Insert one end of the charging cable into the charging slot of the battery, and connect the other end to an AC power supply (100-240V) through the adapter.

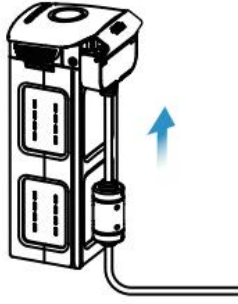

**Battery level indicator:** The LED indicators on the battery of the aircraft flash from the left to the right, indicating the current battery level during the charging. The indicators will turn off when the battery is full.

Battery level indicator status (during charging)			
0%~25%	26%~50%	51%~75%	76%~100%
- Green LED is normally on		- Green LED flashes	

2. **Remote controller:** Insert the Type-C cable into the Type-C port of the remote controller.

**Note**

- Fully charge the batteries of the aircraft and remote controller before the flight.
- It takes about 90 minutes to fully charge the aircraft and about 120 minutes to fully charge the remote controller.
- Disconnect the charger from the battery of the aircraft or remote controller after the charging is complete.

## 3.2 Prepare the Remote Controller

### 3.2.1 Unfold the Remote Controller

The remote controller is folded in the packing box. Extend the antennas before you use the remote controller. For details, see  Section 2.2.2 Adjust the antennas.

### 3.2.2 Turn On/Off the Remote Controller

- **Turn on/off**

Press and hold the power button for 2 seconds until you hear a short beep.

---

 **Important**

- Always turn on the remote controller before you turn on the aircraft.
  - Always turn off the aircraft before you turn off the remote controller.
- 

### 3.2.3 Pair the Aircraft with the Remote Controller

 By default, the remote controller is linked to the aircraft before delivery. When you need to pair them again, you can refer to Section 2.2.2.

## 3.3 Prepare the Aircraft

### 3.3.1 Unfold the Aircraft

#### 1. Remove/Mount the Gimbal Protective Cover

Remove the gimbal support before you turn on the aircraft, as shown in the following figure.

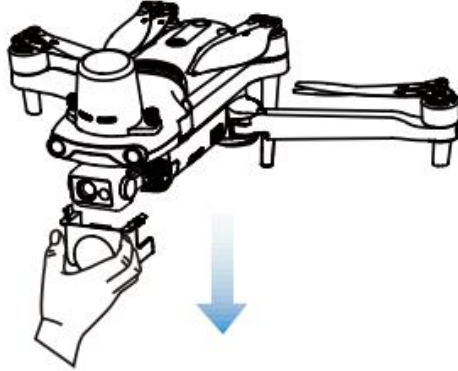

After you turn off the aircraft, you need to put the protective cover back on the gimbal to prevent damage.

#### 2. Extend the Arms and Propeller

- Always unfold the aircraft arm before you turn on the aircraft.
- Unfold the front arm first and then the rear arm.

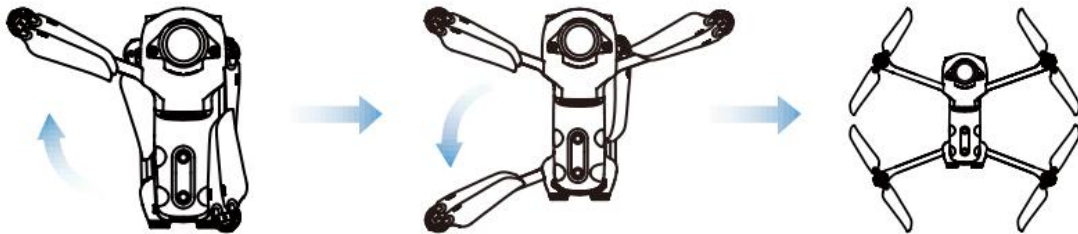

---

#### ! Important

- Turn off the aircraft before you fold the arms.
- 

### 3.3.2 Propeller

EVO II RTK Series V3 aircraft uses a propeller that is easy to remove.

---

#### ⚠ Warning

- Turn off the aircraft before you install or remove the propeller.



**! Important**

- Wear protective gloves for installing or removing the propeller.

## 1. Mount the Propeller

1. Make sure that the aircraft has been turned off.
2. Select the propeller that is compatible with each motor.
3. Press the propeller firmly and rotate it in the locking direction to firmly secure the propeller.



Propeller	With a white icon	Without a white icon
Installation position	Mount the propeller onto the mounting plate with a white mark.	Mount the propeller onto the mounting plate with no white mark.
Legend description	 Locking direction: Rotate the propeller in the direction as shown in the figure to secure it.  Unlocking direction: Rotate the propeller in the direction as show in the figure to remove it.	

## 2. Remove the Propeller

1. Turn off the aircraft.
2. Press the propeller firmly and rotate it in the unlocking direction to remove the propeller.

**! Important**

- Before the flight, check every propeller is firmly secured.
- Do not use a damaged propeller.
- Do not touch a rotating propeller or motor.
- Always remove the propeller before you test the motor.

### 3.3.3 Compass Calibration

Generally, you do not need to calibrate the compass as it has already been calibrated before the delivery. Perform the following steps to calibrate your compass if one of the following errors occurs: the compass shows incorrect information, the aircraft is flying in a wrong direction that is not consistent with the input, or the location where the aircraft is flying is far away from the calibration location.

---

#### **Warning**

- The compass is very easy to be affected by electromagnetic interference. Electromagnetic interference may lead to compass errors and degradation in flight quality. If the compass still cannot work properly after the calibration, fly the aircraft to other places and calibrate the compass again.
- 

Pay attention to following precautions when calibrating your compass:

- Select an open outside area.
- Keep it away from all sources of magnetic interference, such as magnets or steel reinforcements. Proximity to large structures may also affect the calibration results.
- Keep it away from underground and overhead power lines.
- Do not carry ferromagnetic materials with you during calibration (such as keys or magnetic jewelry).
- Keep it away from all electronic devices such as mobile devices that may interfere with calibration.

### 3. Calibration Procedure

1. Turn on the aircraft and remote controller, launch the Autel Explorer App, go to the camera page, and click the Settings button (). When the calibration starts, the LED indicator on the back of the aircraft flashes yellow.
2. Hold the aircraft horizontally and rotate it until the LED indicator on the back of the aircraft displays a solid green light.
3. Hold the aircraft vertically, with the nose pointing downwards, and then rotate it until the LED indicator on the back of the aircraft glows solid green.
4. Hold the aircraft, with the nose pointing forwards and the side plane downwards, and then rotate it until the LED indicator on the back of the aircraft glows solid green.

---

 **Note**

- If the calibration fails, the LED indicator on the back of the aircraft blinks red. In this case, repeat the above steps.
-



# Chapter 4 Flight Operation

## 4.1 Pre-flight Checklist

Observe the following steps to perform a comprehensive pre-flight check:

- The aircraft, remote controller, and your mobile device are all fully charged.
- The gimbal protective cover has been removed.
- The propellers are mounted correctly and working properly.
- The antennas have been adjusted according to the instructions described in Section 2.2.2.
- The aircraft has already paired with the remote controller.
- The firmware has been upgraded to the latest version.
- Make sure that you are familiar with flight control operations.
- Check whether the flight region is open with no blocking obstacles.
- Check the weather conditions including the temperature and wind speed.
- Check whether the camera lens of the aircraft and sensors are clean.

## 4.2 Flight Operation

The aircraft provides three command stick modes: mode 1, mode 2, and mode 3. In each mode, you can control the aircraft in a different way. By default, mode 2 is used. You can switch the modes using the Autel Explorer App. We recommend that beginners use mode 2.

### 1. Basic Procedure

1. Place the aircraft in an open area. Stand at least 3 meters away from the tail of the aircraft.
2. Turn on your remote controller.
3. Turn on the aircraft and wait for the LED indicator at the tail to slowly flash green.
4. Start the motor using the remote controller and make the aircraft take off.
5. Carefully control the aircraft within your range of visibility.
6. Land the aircraft and turn off the motor.

#### 4.2.1 Takeoff (Mode 2)

- As shown in the following figure, press the left and right stick for 2 seconds to start the motor.

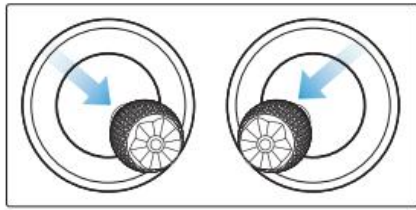

or

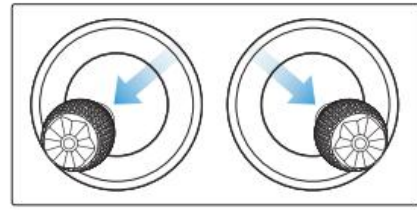

- Slowly push the left stick upwards:

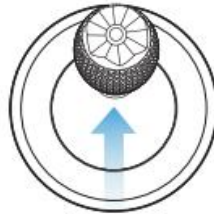

---

#### **Warning**

- The motor will generate heat during the operation. Operate it with care.
  - When the battery level is 15% or even lower than that, the aircraft cannot take off.
- 

### 4.2.2 Control with Command Sticks (Mode 2)

---

#### **Tip**

- If you are the first time to control the aircraft, move the stick gently until you are familiar with the operations.
- 

#### **1. Left command stick**

Push the stick upwards and downwards to ascend or descend the aircraft. Push the stick to the left or right side to control the orientation of the aircraft.

## Left command stick

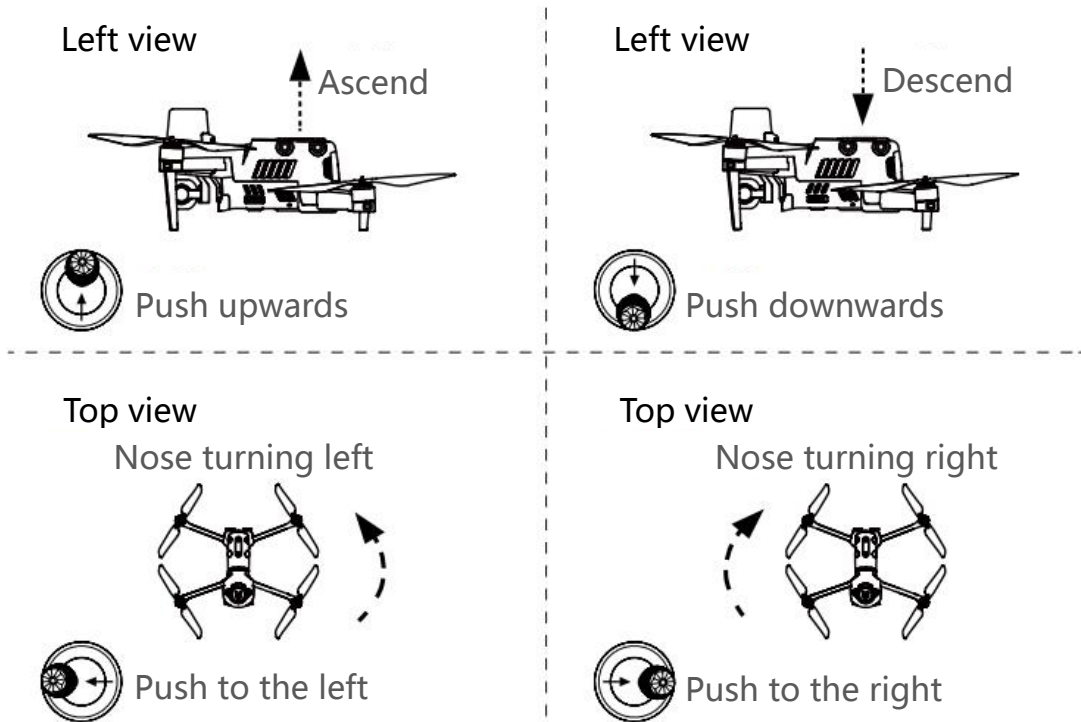

## 2. Right command stick

Push the stick upwards and downwards to move the aircraft forwards and backwards. Push the stick to the left or right to move the aircraft to the left or right.

## Right command stick

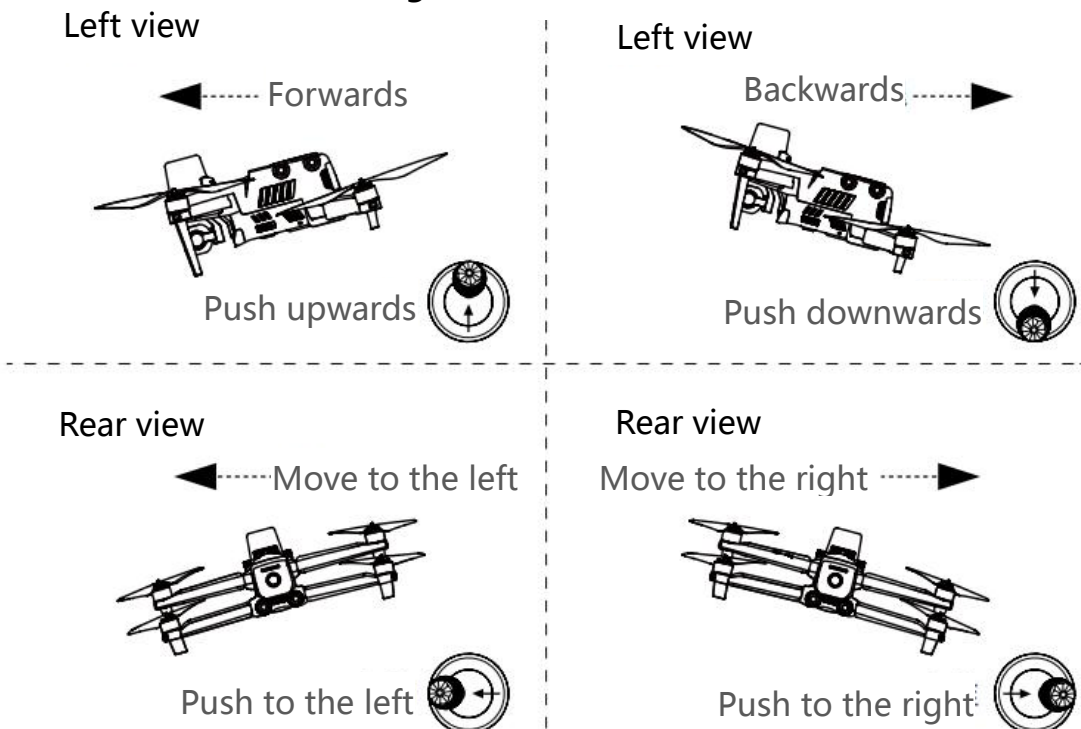

### 4.2.3 Landing

EVO II RTK Series V3 can be manually or automatically landed. The procedure for landing an aircraft is as follows:

#### 1. Manual landing

1. Find an appropriate landing position (flat and open area).
2. When the aircraft arrives above the target position, release the command stick to hover the aircraft.
3. Slowly push down the left command stick to land the aircraft.
4. After the aircraft lands on the ground, push the left command stick all the way until the motor is turned off.

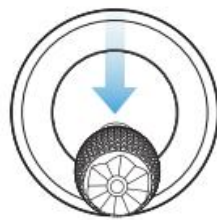

---

#### Note

- When the low battery warning (25%) is displayed, the LED indicator on the back of the aircraft flashes red. In this case, you must immediately let the aircraft to land on a safe place.

---

#### 2. Automatic landing

When one of the following errors occur, failsafe will be triggered and the aircraft will automatically land from the current position:

- A low battery warning is displayed in a non-GPS environment.
- A critical low battery warning is displayed.

# Chapter 5 Maintenance and Service

## 5.1 Firmware Updates

To achieve the optimal performance of EVO II RTK Series V3 aircraft, Autel Robotics will update relevant firmware when necessary. You can download a unified firmware upgrade package from the official website. The package includes the latest versions of multiple firmware, such as the flight controller, gimbal, camera, intelligent battery, and remote controller.

---

### Important

Before you upgrade the firmware, ensure that:

- The aircraft motor is not rotated.
  - The battery of the aircraft and remote controller is not lower than 25%.
  - The SD card has sufficient space to store firmware files.
- 

### 1. Download and upgrade the firmware

#### ➤ Method 1

1. Download the firmware upgrade package from the official website of Autel Robotics: [www.autelrobotics.cn/download/11](http://www.autelrobotics.cn/download/11)
2. Insert the SD card into the computer and extract the downloaded files into the root directory of the SD card. Remove the SD card from the computer.
3. Turn on the aircraft and remote controller.
4. Insert the SD card into the aircraft to automatically start the upgrade process. You can check the upgrade process through the app.
5. Restart the aircraft and remote controller before you use the product again.

#### ➤ Method 2

When the system detects a new firmware version, the Autel Explorer App will automatically pop up a prompt message after you connect the App with the aircraft, reminding you to download and install the firmware. Follow the promoted instructions to download and upgrade the firmware.

---

**! Important**

- The firmware update takes about 15 minutes. During the upgrade, do not turn off the aircraft or remote controller, start the motor, or remove the SD card from the camera.
  - After the upgrade, the remote controller may be disconnected from the aircraft. To pair them again, refer to Section 2.2.2.
- 

## 5.2 Troubleshooting

**Question 1: An error is found when the aircraft performs the self-check (the LED indicator at the tail of the aircraft glows solid red).**

- This is a hardware issue. Please contact Autel Robotics' customer support: [www.autelrobotics.cn/page/service](http://www.autelrobotics.cn/page/service)

**Question 2: If the motor cannot start, check the following:**

- Check whether the remote controller is paired with the aircraft.
- Check whether the remote controller is correctly calibrated.
- Check whether the aircraft is fully charged.
- Check whether the compass is correctly calibrated.
- Check whether the GPS is available (when you enable the beginner mode).

**Question 3: If the aircraft cannot take off after you start the motor, check the following:**

- Check whether the aircraft is in a No Fly Zone.
- Check whether the aircraft is placed on a flat surface.

**Question 4: Why is the flight time shortened?**

- The common causes are low temperature and wind speed.

**Question 5: There is no response from the remote controller when pairing it with the aircraft.**

- Check whether there is a metal object, mobile device or other remote controller near.

**Question 6: The video link fault occurs or is interrupted often.**

- Check whether there is any magnetic or signal interference source near the aircraft and remote controller.

**Question 7: The camera automatically turns off during recording.**

- Do not pull out the micro SD card from the camera. Restart the camera and wait for the video file to be stored as much as possible.

**Question 8: The video link is interrupted when the aircraft is not out of your sight.**

- Enable auto-return and let the aircraft return to the home point.

**Question 9: What precautions should I follow when using the omnidirectional binocular vision sensing system?**

- Ensure that 12 cameras are clean without being blocked before the flight. "Omnidirectional" means that the system can sense objects in six directions, including front, rear, left, right, up, and down.
- A blind zone of 30° degrees exists in the four diagonal directions of the aircraft. Pay attention to the surrounding environment and safety prompt messages of the app.
- Obstacles can be detected by checking the texture of their surfaces. The detection function cannot work properly for objects with no texture, repeated texture, or a surface of pure color, moving objects, or tiny objects.

**Question 10: The accurate landing cannot work properly.**

- This feature can be implemented by the binocular camera on the rear of the aircraft. The camera detects the ground texture when the aircraft takes off.
- However, if the ground does not have any texture or the camera on the rear of the aircraft is damaged, this feature cannot work properly.

**Question 11: The omnidirectional binocular vision sensing system cannot work properly.**

- Restart the aircraft and check whether the system can work properly this time.

**Question 12: The video is tilted during the flight.**

- Place the aircraft horizontally and keep it still.
- Use the app to calibrate the gimbal.
- If the problem persists, adjust the gimbal according to the instructions described in the relevant section.

**Question 13: The lens of the binocular camera is dirty.**

- Use a cleaning cloth to wipe the lens. Use the glasses cleaning cloth in the

packing box.

**Question 14: A visual error occurs during the flight.**

- Use the calibration tool in your PC to calibrate binocular parameters. You can download the calibration tool for your PC from the official website.

## 5.3 Storage and Maintenance

To ensure the optimal performance of EVO II RTK Series V3 aircraft, read and observe the maintenance instructions in this section carefully.

- Store the aircraft, battery, and remote controller in a clean, dry, cool, and well-ventilated environment.
- Protect the aircraft from direct sunlight when it is not used.
- Wipe your hands before you operate your drone.
- Clean the camera lens with the soft cloth dipped in alcohol or mild window cleanser. Do not use any strong detergents or chemicals.
- Keep the battery charger away from any conducting materials.
- Avoid the aircraft and its accessories from falling on a hard surface. Carefully check every component whenever a collision occurs. Contact Autel Robotics customer support for any damage.
- Only use the accessories authorized by Autel Robotics, such as charger. No warranty shall be provided for any accident caused by the use of unapproved accessories.

## 5.4 Warranty

For users who purchase the products from authorized retailers, Autel Robotics guarantees that in normal use, the Autel Robotics product you buy is free from defects in material or workmanship. The warranty period for this product starts on the day you received the product. If you cannot provide a valid proof of purchase such as a purchase invoice, the warranty start date will be defined as 90 days after the delivery date printed on the device or by Autel Robotics.

---

**! Important**

- For the detailed after-sales policy, visit the official website of Autel Robotics: <http://www.autelrobotics.cn/page/policy.html>



---

## 5.5 Customer Service

This section includes the information on technical support, maintenance service, and application for replacement and spare parts.

### 5.5.1 Technical Support

If you have any problems or questions regarding our product, contact Autel Robotics' customer support:

China

Tel: 400-800-1866

Website: [www.autelrobotics.cn](http://www.autelrobotics.cn)

North America/Europe

Tel: (844) 692-8835

Email address: [support@autelrobotics.com](mailto:support@autelrobotics.com)/[support.eu@autelrobotics.com](mailto:support.eu@autelrobotics.com)

Website: [www.autelrobotics.com](http://www.autelrobotics.com)

### 5.5.2 Maintenance Service

If you want to send your device for maintenance, please send an email to [after-sale@autelrobotics.com](mailto:after-sale@autelrobotics.com) or call 400-800-1866 to contact Autel Robotics' customer support.

---

#### Note

- All content of the product may be deleted during maintenance. We recommend that you create a backup copy of the data in the product before delivering the product for warranty service.
-

## Chapter 6 Appendix

### 6.1 Unlock No-Fly Zones

EVO II RTK Series V3 aircraft can automatically identify No-Fly Zones and avoid these zones by default during the flight. This ensures that the aircraft complies with the lawful requirements on flight zones.

---

 **Note**

- You must ensure that you abide by all relevant flight rules and regulations.
- If you want unlock a No-Fly Zone, visit the official website of Autel Robotics and follow the instructions on the page to submit an application:

[www.autelrobotics.cn/page/noflight](http://www.autelrobotics.cn/page/noflight)

---

## 6.2 Specifications

<b>Aircraft</b>	
Takeoff weight (including the RTK)	EVO II Pro RTK V3: 1237 g±0.5 g EVO II Dual 640T RTK V3: 1250g±0.5 g
Dimensions (including the RTK, length x width x height)	230x130x143 mm (folded) 260x355x143 mm (extended)
Diagonal length	397 mm
Maximum flight time (no wind)	36 minutes
Maximum hovering time (no wind)	32 minutes
Maximum flight speed	20 m/s (in ludicrous mode)
Maximum ascent speed	8 m/s (in ludicrous mode)
Maximum descent speed	4 m/s (in ludicrous mode)
Maximum flight altitude	7000 meters
Wind resistance	Level 8 (hover), level 6 (flying)
Operating temperature	-10 ~ 40°C
*Operating frequency	902-928 MHz(FCC) 2.400-2.4835 GHz 5.725-5.850GHz (Countries except for Japan) 5.650-5.755GHz (Japan)
Transmission power	900M FCC/ISED: ≤31 dBm 2.4G FCC/ISED: ≤32 dBm SRRRC/CE/MIC/RCM: ≤20 dBm 5.8G (Countries except for Japan); 5.7G (Japan) FCC/ISED/SRRRC/MIC: ≤33 dBm CE/RCM: ≤14 dBm

Hovering accuracy (mild wind or no wind)	Equipped with the RTK module and the RTK is working properly: Vertical: $\pm 0.1$ m; Horizontal: $\pm 0.1$ m Not equipped with the RTK module: Vertical: $\pm 0.1$ m (when the vision positioning is active), $\pm 0.5$ m (when the GNSS positioning is active); Horizontal: $\pm 0.3$ m (when the vision positioning is active), $\pm 1.5$ m (when the GNSS positioning is active);
Built-in storage	8G
Supported SD card	Max. capacity: 256GB (Class 10 or UHS-3)

<b>GNSS</b>	
Single-frequency and highly-sensitive GNSS	GPS+BeiDou+Galileo (Asia) GPS+GLONASS+Galileo (Other regions)
Multi-frequency, multi-system, and high-precision RTK GNSS	Used frequency points: GPS: L1/L2; GLONASS: L1/L2; BeiDou: B1/B2; Galileo: E1/E5
	First positioning time: < 50 s
	Positioning accuracy: Vertical: 1.5 cm + 1 ppm (RMS) Horizontal: 1 cm + 1 ppm (RMS) 1 ppm: For every 1 km increase in distance, the accuracy will be 1 mm less.

<b>Gimbal</b>	
Mechanical range	Pitch: $-135^{\circ}$ to $+45^{\circ}$ Heading: $-100^{\circ}$ to $+100^{\circ}$
Controllable range	Pitch: $-90^{\circ}$ to $+30^{\circ}$ Heading: $-90^{\circ}$ to $+90^{\circ}$
Stabilization	3-axis
Maximum control speed (tilt)	$300^{\circ}/s$
Angular vibration range ( $^{\circ}$ )	$\pm 0.005^{\circ}$

<b>Sensing system</b>	
Forward	Accurate measurement range: 0.5 - 18 m Effective sensing speed: < 12 m/s FOV: horizontal: 60°, vertical: 80°
Backward	Accurate measurement range: 0.5 - 16 m Effective sensing speed: < 12 m/s FOV: horizontal: 60°, vertical: 80°
Upward	Accurate measurement range: 0.5 - 10 m Effective sensing speed: < 5 m/s FOV: horizontal: 65°, vertical: 50°
Downward	Accurate measurement range: 0.5 - 10 m Effective sensing speed: < 5 m/s FOV: horizontal: 100°, vertical: 80°
Left and right	Accurate measurement range: 0.5 - 10 m Effective sensing speed: < 5 m/s FOV: horizontal: 65°, vertical: 50°
Operating environment	Forward, backward, left and right: Surface with clear patterns and adequate lighting (> 15 lux, indoor fluorescent lamp, environment with normal light exposure) Upward: surface built from special materials that can reflects light diffusely and diffuse reflection > 20% (such as walls, trees. and persons) Downwards: the ground has rich texture and sufficient light. (> 15 lux, indoor fluorescent lamp, environment with normal light exposure) surface built from special materials that can reflects light diffusely and diffuse reflection > 20% (such as walls, trees. and persons)

<b>EVO II Pro RTK V3 Visual Camera</b>	
Image Sensor	1-inch CMOS
Effective pixels:	20M
Lens	FOV: 82° Equivalent focal length: 29 mm Aperture: f/2.8 - f/11 Focus range: 0.5 m ~ ∞
ISO range	Video: ISO100 - ISO44000

	Photo: ISO100 - ISO6400
Digital zoom	1 - 16x (max. 3x lossless zoom)
Photo format	JPG (default)/DNG/JPG+DNG
Photo-taking mode	Single (default)/burst/AEB/periodic/HDR
Photo resolution	5472x3648 (3:2, default) 5472x3076 (16:9) 3840x2160 (16:9)
Video format	MP4/MOV (MPEG-4 AVC/H.264, HEVC/H.265)
Video resolution	5472x3076 P30/P25/P24 3840x2160 P60/P50/P48/P30 (default)/P25/P24 2720x1528 P60/P50/P48/P30/P25/P24 1920x1080 P60/P50/P48/P30/P25/P24
Max bit rate	120 Mbps
Supported file systems	FAT32/exFAT

<b>EVO II Dual 640T RTK V3 Thermal Imaging Camera</b>	
Infrared thermal imaging sensor	Uncooled infrared focal plane detector made out of vanadium oxide
Sensor resolution	640x512
Wavelength	8 ~ 14 $\mu\text{m}$
Focal length	13 mm
FOV	H33°V26°
Pixel size:	12 $\mu\text{m}$
Digital zoom	1 - 16 times
Accurate distance for temperature measuring	2 - 20 meters
Photo taking mode	Single/burst/periodic
Photo resolution	Infrared mode: 640x512 Picture-in-picture: 1920x1080, 1280x720
Photo format	JPG (IRG files)
Video format	MP4/MOV (H.264/H.265)
Video resolution	640x512 30 fps

Temperature measurement precision	±3°C or ±3% of the reading (the larger value is used) @Environment temperature -20°C - 60°C
Temperature measurement range	High gain mode: -20° - +150° Low gain mode: 0° - +550°

<b>EVO II Dual 640T RTK V3 Visual Camera</b>	
Image Sensor	1/1.28-inch CMOS
Effective pixels:	50 million
Lens	FOV: 85° Equivalent focal length: 23 mm Aperture: f/1.9 Focus range: 0.5 m ~ ∞
ISO range	Video: ISO100 - ISO64000 Photo: ISO100 - ISO6400
Digital zoom	1 - 16x (max. 4x lossless zoom)
Photo format	JPG (default)/DNG/JPG+DNG
Photo-taking mode	Single (default)/burst/AEB/periodic/HDR
Photo resolution	8192x6144(4:3) 096 × 3072 (4:3, default) 3840x2160(16:9)
Video format	MP4/MOV (MPEG-4 AVC/H.264, HEVC/H.265)
Video resolution	3840x2160P60/P50/P48/P30(default)/P25/P24 2720x1528P60/P50/P48/P30/P25/P24 1920x1080P60/P50/P48/P30/P25/P24
Max bit rate	120 Mbps
Supported file systems	FAT32/exFAT

<b>Autel Smart Controller V3</b>	
Maximum transmission distance (unobstructed, free of any interference)	15 km(FCC), 8 km(CE)
*Operating frequency	902-928 MHz(FCC) 2.400-2.4835 GHz 5.725-5.850GHz (Countries except for Japan) 5.650-5.755GHz (Japan)

Transmission power	FCC: ≤33 dBm CE: ≤20 dBm@2.4G, ≤14 dBm@5.8G SRRC: ≤20 dBm@2.4G, ≤33 dBm@5.8G/5.7G
Storage space	Built-in 128GB
Video output port	HDMI
Battery	Capacity: 5800 mAh Voltage: 11.55V Type: LiPo Energy: 67 Wh Charging time: 120 minutes
Battery endurance	3 hours (maximum brightness) 4.5 hours (50% brightness)
Operating temperature	-20°C ~ 40°C
Dimensions	303×190×87 mm (folded antennas) 303×273×87 mm (extended antennas)
Weight	1150 g (without the protective cover) 1250 g (with the protective cover)
Satellite positioning module	GPS/GLONASS/Galileo/BeiDou

<b>Battery</b>	
Battery capacity	7100 mAh
Voltage	11.55
Battery type	LiPo 3S
Battery energy	82 Wh
Net weight	365 g
Environment temperature for charging	5 ~ 45°C
Temperature & humidity for storage	-10 ~ 30°C, 65±20%RH
Ideal temperature for storage	22~28°C
Maximum charging power	93W
Charging time	90 minutes



<b>Charger</b>	
Input	100-240V, 50/60 Hz, 1.5A
Output	13.2V $\equiv$ 5A 5V $\equiv$ 3A 9V $\equiv$ 2A 12V $\equiv$ 1.5A
Voltage	13.2V
Rated power	66W

Note:

\* The used frequency band varies in different countries and regions.