

Skydio X2E Color/Thermal

Unmatched autonomy meets enterprise performance

Skydio X2E Color/Thermal is the ultimate UAS solution for aerial situational awareness and search & rescue missions. X2E is powered by Skydio Autonomy Enterprise, an AI-driven autonomous flight engine that enables unparalleled 360° obstacle avoidance, autonomous tracking, GPS-denied navigation, and complete workflow automation. X2E is designed with a ruggedized, foldable airframe, GPS-based night flight, strobing lights in visible and IR wavelength, and a dual sensor payload with a 12MP color camera and FLIR® 320x256 thermal sensor. Built for enterprises and first responders, Skydio X2E is designed and assembled in the USA, and is compliant with the National Defense Authorization Act (NDAA).

Advanced software add-ons

- ⊕ **Skydio 3D Scan™:** Adaptive scanning to automate the image capture process to document complex structures and generate 3D models with comprehensive coverage and ultra-high resolution. Perform higher quality inspections and documentation faster and with minimal pilot training.
- ⊕ **Skydio Cloud:** Enables federated fleet management and seamless upload of flight media. No more manual handling of SD cards and hard drives.



RUGGED, PORTABLE, DEPLOYS IN UNDER 75 SECONDS

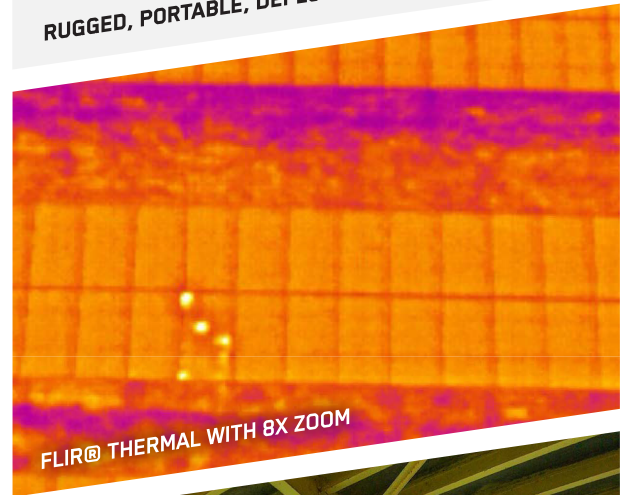

FLIR® THERMAL WITH 8X ZOOM



VISION-BASED NAVIGATION FOR GPS-DENIED OPERATIONS

WIRELESS RANGE

Up to 3.7 mi / 6 km

FLIGHT TIME

Up to 35 min

CYBERSECURITY

AES-128 wireless encryption

X2E Color/Thermal & Controller Specs

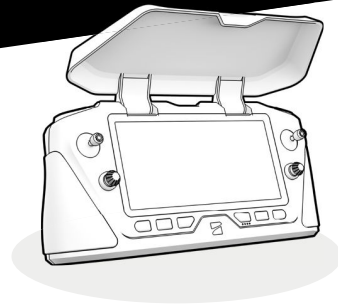
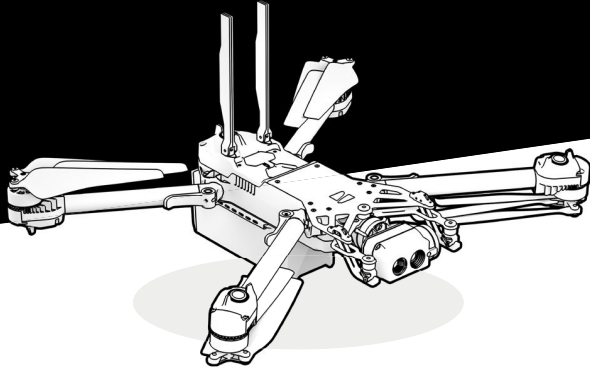

AIRCRAFT

DIMENSIONS (UNFOLDED, FLYING)	26.1" X 22.4" X 8.3" (66 x 56 x 20 cm)
DIMENSIONS (FOLDED, NO BATTERY)	11.9" X 5.5" X 3.6" (30 x 15 x 10 cm)
WEIGHT (WITH BATTERY)	1325 g
FLIGHT TIME	Up to 35 minutes
MAX FLIGHT SPEED (SEA LEVEL, NO WIND)	25 mph (40 km/h)
MAX WIND SPEED RESISTANCE	23 mph
MAX SERVICE CEILING (ABOVE SEA LEVEL)	Up to 12,000 ft
OPERATIONAL TEMPERATURE RANGE	-10°C to 43°C

SKYDIO AUTONOMY ENTERPRISE

MAIN PROCESSOR	NVIDIA Tegra X2 SOC
CAMERA CONFIGURATION	6x cameras in trinocular configuration top and bottom
ENVIRONMENT COVERAGE	True 360°
OBSTACLE AVOIDANCE COVERAGE	Omnidirectional
3D WORLD MODEL UPDATE RATE	> 1 million points per second
WORLD MODEL-TO-ACTION UPDATE RATE	500 iterations per second
ONBOARD AI	9 custom deep networks used in flight
USER-SELECTABLE SUBJECTS FOR TRACKING	People and motor vehicles
OBJECT TRACKING AND IDENTIFICATION	Up to 20 simultaneous objects of interest
CALIBRATION	Automated calibration of lens parameters, cameras, wind speed, and air density
ADVANCED AI-PILOT ASSISTANCE	360 Superzoom, Close Proximity, Obstacle Avoidance, Point-of-Interest Orbit, Track-in-Place, Vertical View, Visual Return-to-Home

CONTROLLER

DIMENSIONS	10.75" x 5.25 x 3.0"
WEIGHT	1130 g
APPLICATIONS	Skydio Enterprise App
WIRED LINKS	USB, (via dongle) HDMI
OPERATING FREQUENCIES	5 GHz
MAX RANGE	Up to 6 km (5 GHz)
VIDEO FEED	720p at 30 fps

PRIMARY CAMERA SYSTEM

COLOR SENSOR TYPE	Sony IMX577 1/2.3" 12.3MP CMOS
COLOR LENS FOCAL LENGTH	41mm (35mm format equivalent)
COLOR VIDEO RESOLUTION	4K / 60 fps with 16x digital zoom
COLOR VIDEO FORMAT	MPEG-4 (AVC/H.264, HEVC/H.265)
COLOR STILL RESOLUTION	4056x3040 (12 MP)
COLOR DYNAMIC RANGE	13 stops
PITCH CONTROLLABLE RANGE	-110° to +45° (-110° to +90° with AEF)
THERMAL SENSOR TYPE	FLIR Uncooled VOx microbolometer
THERMAL RESOLUTION	320x256
THERMAL LENS FOCAL LENGTH	9.1mm
THERMAL FRAMERATE	30fps

SYSTEM SECURITY

WIRELESS ENCRYPTION	AES-128
FIRMWARE	Signed and encrypted
CONTROLS	Ability to provision and deprovision devices
INFRASTRUCTURE	Key provisioning burned-in at time of manufacture



Contact enterprise@skydio.com today to learn more about integrating Skydio X2.

Designed and assembled in the USA